

IRIS Tilt Switch and Controller

The IRIS Tilt Switch and Controller is a powerful control device that enables you to measure and respond to rotational movements in any direction with reference to

the unchanging gravity vector. Use IRIS to maintain platform levelness, avoid tipover conditions, prevent out-of-range movement, and for many other control requirements.



MULTI-FEATURED INCLINOMETER

IRIS detects angular position with an on-board electrolytic tilt sensor, which has no mechanical moving parts to break or wear out. The standard firmware includes five user-programmable set points for tilts in different directions. When a selected threshold is reached, the circuitry sets the output high on one of the pins in the H3 control connector. Three additional control outputs are available for firmware upgrades in custom applications.

IRIS is also a multi-featured inclinometer, which contributes to its powerful control capabilities. Data sampling rates, which are also the threshold checking rates, are user-selectable, and inclination data in ASCII format can be continuously output to external devices. Firmware commands include averaging, autozero and other powerful functions.

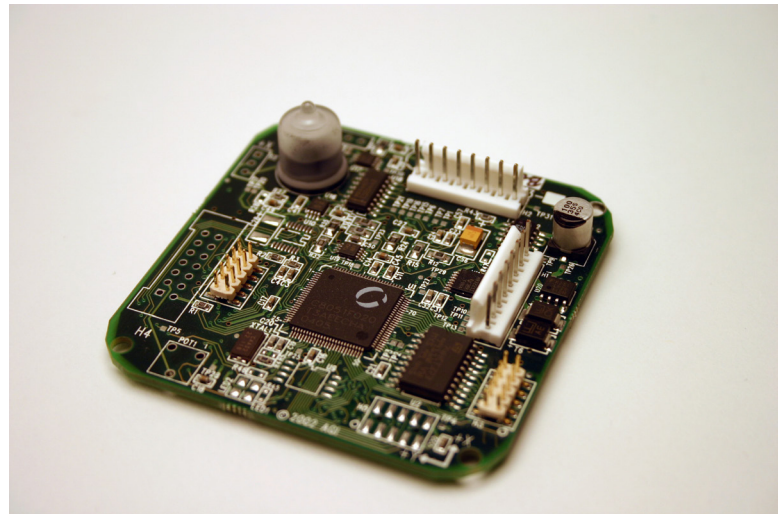

A FULL-FEATURED INCLINOMETER

IRIS is a versatile biaxial clinometer that measures rotational movement in two orthogonal vertical planes. Serial ASCII data are output as either RS232 or RS422(485) signals for recording by an external terminal or computer. Important features are firmware-controlled and user-selectable. These include output data rates and formats, signal averaging, autozero (nulling), and internal data storage (logging). Several output data formats are provided, all of which include X tilt, Y tilt, Temperature and Serial Number information.

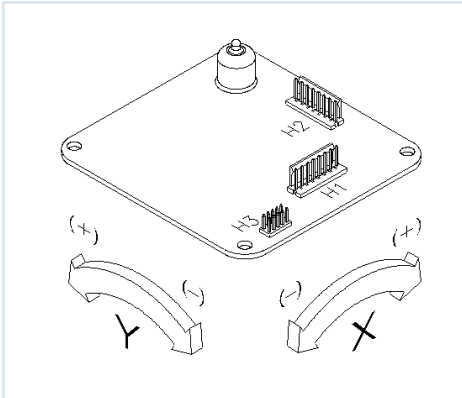

A POWERFUL CONTROL DEVICE

The firmware on the standard IRIS board has 5 user programmable thresholds. When a tilt measurement is taken, it is compared to each of these thresholds: +X tilt, -X tilt, +Y tilt, -Y tilt and tilt in any direction. If the measurement exceeds one or more of the thresholds, the corresponding output pin(s) in the H3 connector, are set high (5V), as shown below. If the threshold is not exceeded, the output remains at 0 Volts. The reference angle for the threshold measurement is selected using the autozero command. Threshold checking may be turned off with a single firmware command when it is not needed.

The standard IRIS firmware also allows the user to set the hysteresis of the control thresholds. The hysteresis is used as follows: After an H3 output pin is set high, it is not set low again until the tilt reading has reached a level that is below the threshold by an amount equal to the hysteresis (see diagram).

IRIS includes 3 additional control output pins in the H3 connector, bringing the total to 8. The 3 additional pins are not active in the regular versions of the product, but may be implemented for your application by custom programming by our software engineers. Each of the 8 control outputs is separately programmable. Another custom option is “normally high” control output instead of the standard “normally low” output. With “normally high” controls the voltage level of the H3 pin is 5V until a threshold is reached, at which time it switches to 0V.

In the regular versions of IRIS the control pins in connector H3 are all set high for approximately 150 milliseconds on power up, after which they reset to their “normally low” value of 0V until a tilt threshold is detected.

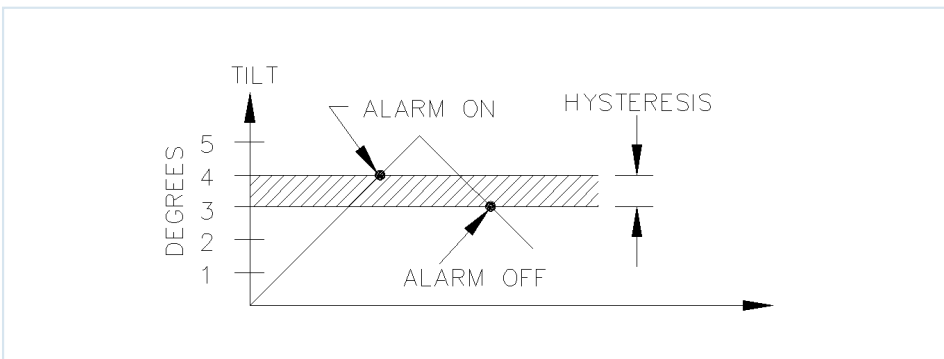
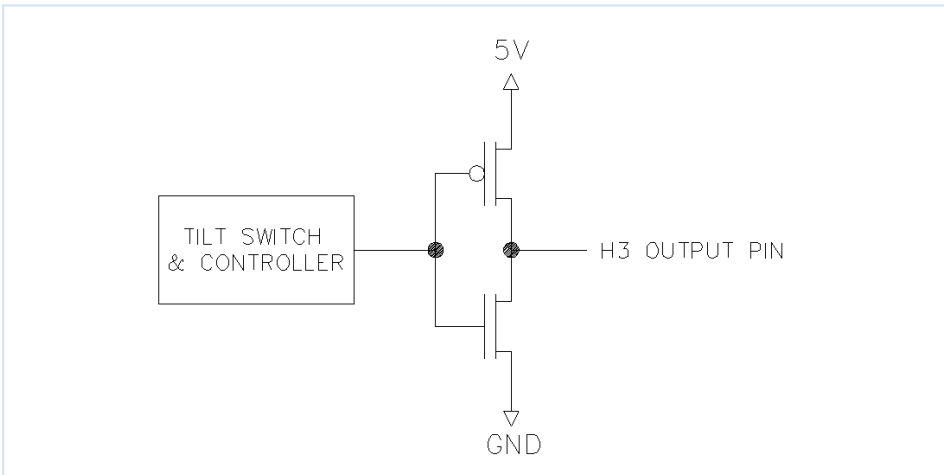

Tilt Switch and Controller

CONNECTOR PINOUT TABLES

H1 PIN	FUNCTION	H2 PIN	FUNCTION
1	Power (7-28 VDC)	1	Power (7-28 VDC)
2	Ground	2	Ground
3	Tx (RS232)	3	Ground
4	Rx (RS232)	4	Not used
5	Tx+ (RS422)	5	Not used
6	Tx- (RS422)	6	Not used
7	Rx- (RS422)	7	Not used
8	Rx+ (RS422)	8	Not used

H3 PIN	FUNCTION
1	-X tilt threshold
2	+X tilt threshold
3	-Y tilt threshold
4	+Y tilt threshold
5	Optional threshold*
6	Optional threshold*
7	Optional threshold*
8	Threshold in any direction
9	Ground
10	3.3 VDC output

* Custom firmware only

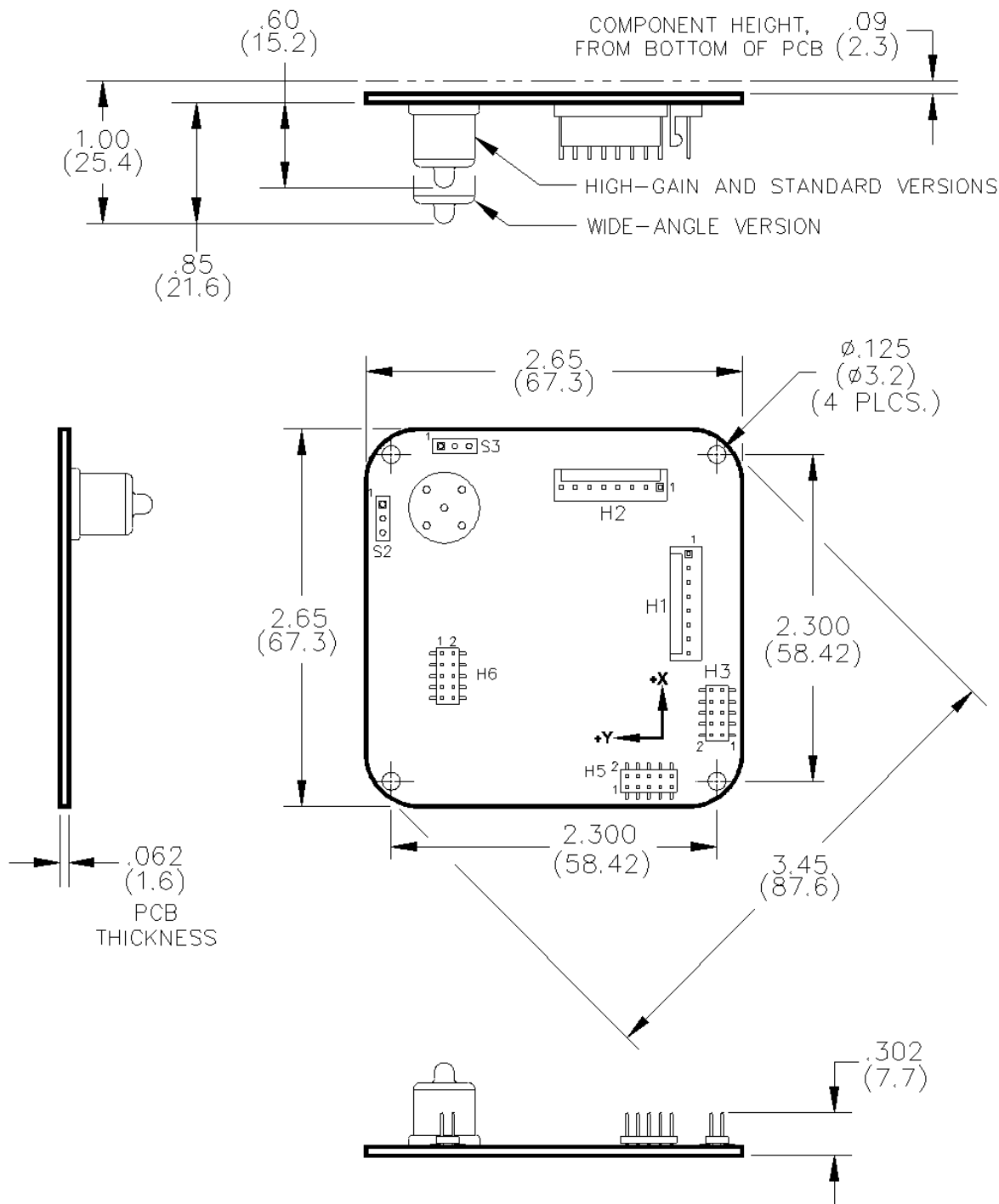

Overall Dimensions of the IRIS Tilt Switch and Controller

	HIGH-GAIN VERSION	STANDARD VERSION	WIDE-ANGLE VERSION
ANGULAR RANGE	±10 degrees (20 degree span)	±25 degrees (50 degree span)	±50 degrees* (100 deg. span)
RESOLUTION	0.005 degree	0.012 degree	0.025 degree
ACCURACY	±1% of full span		
TIME CONSTANT, T	150 msec; output is proportional to $1 - e^{-t/T}$ where t = time in seconds		
NATURAL FREQUENCY	7 Hz; available with viscous sensor to filter vibrations		
TEMPERATURE COEF.	Span: +0.03%/ °C, Zero: 10-20 arc sec/ °C typical		
SAMPLE RATES	User-selectable from 10/second to 1/hour		
DATA STORAGE	512 kB of nonvolatile Flash Memory available as an option		
SERIAL OUTPUT	RS232 or RS422(485), full duplex. Baud rate: 9600 (default), 19200, 28800, 57600, 115200, 230400		
DATA FORMATS	Formats: NMEA XDR, Trimble proprietary, Ashtech compatible, Simple (x, y, temperature, serial number)		
CONTROL OUTPUTS	8 TTL-compatible CMOS control outputs (0-5 VDC): 5 with user-programmable set points, 3 available for custom applications. Each channel can source up to 20 mA, not to exceed 100 mA for all 8 channels.		
POWER REQUIREMENTS	7-28 VDC @ 30 mA, 250 mV peak to peak ripple max., reverse polarity and surge protected.		
ENVIRONMENTAL	-40° to +85°C operating and storage; 90% humidity, noncondensing		
CONNECTIONS	Three 60cm (2 ft) cables included: Signal (H1), Power (H2), Control Outputs (H3)		
DIMENSIONS & WEIGHT	67 x 67 x 25mm max. (2.6 x 2.6 x 1.0 inches); 31g (1.1 oz)		

*Greater range available

ORDER CODES:

Version	RS232	RS422(485)
High Gain	98021-03	98021-09
Standard	98021-01	98021-07
Wide Angle	98021-02	98021-08

USEFUL ACCESSORIES:

84091	Power Kit: 100-240 VAC wall transformer, power cable with connectors
VISCDAMP	Critically damped sensor to filter vibrations
84089	Mounting plate & hardware
48543	512 kB Flash memory upgrade

APPLIED GEOMECHANICS, INC.

140 Chestnut St.
San Francisco, CA 94111
T: +1-415-364-3200
F: +1-415-861-1448
geomechanics.com
A CARBO Company

