

Model 84800 Conditioning Card

(Single-Channel Signal)

Model 84800 is a compact electronic circuit that provides excitation and signal conditioning for any electrolytic tilt sensor and one LM-35 temperature

sensor. It is designed to generate peak performance from your Applied Geomechanics 755-, 756-, 757- and 758-Series Miniature Tilt Sensors



FOR ANY ELECTROLYTIC TILT SENSOR

Model 84800 will drive signals over cable lengths of 300m. Distances between card and tilt sensor can be up to 100m. Four mounting holes allow easy packaging in OEM and end-user assemblies. A wide input voltage range, transient surge protection and reverse polarity protection are added advantages of using this circuit.

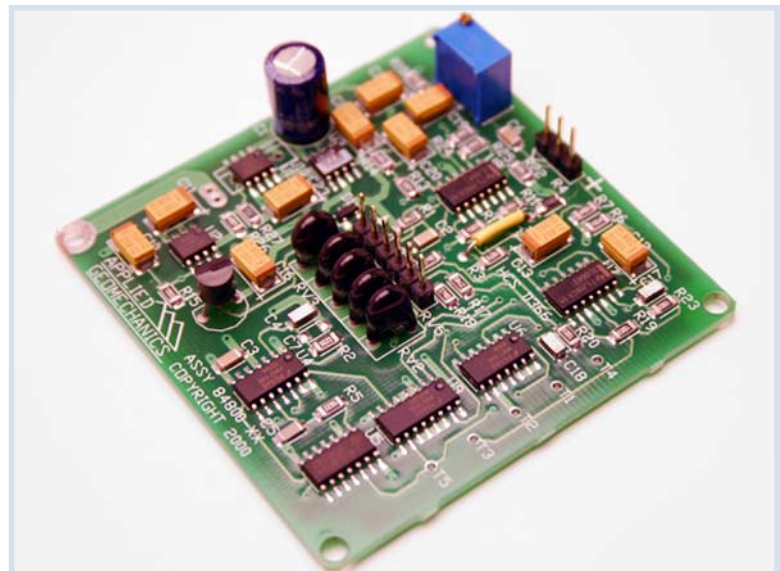

84800 DUAL CHANNEL SIGNAL CONDITIONING CARD

INPUT CHANNELS	Two electrolytic tilt sensors, one LM-35 temperature sensor (included)			
TILT OUTPUT	Two single-ended and two differential analog outputs, proportional to tilt: Output voltage range: ± 8 VDC (single-ended), ± 16 VDC (differential)			
OUTPUT GAINS	Two switchable gains, 10:1 ratio standard, other ratios on request. Toggle switch on board.			
SCALE FACTORS†	WHEN USED WITH: 755-Series Sensors: 756-Series Sensors: 757 & 758-Series Sensors:	HIGH-GAIN 0.1 μ radian/mV* 0.1 degree/V 1.0 degree/V	LOW-GAIN 1.0 μ radian/mV 1.0 degree/V 10 degrees/V	RANGE ± 8000 μ radians ± 8 degrees ± 60 & ± 80 degrees
OUTPUT FILTERS	Two switchable low-pass integrators, roll-off = 6 dB/octave. Time constants = 0.05 and 7.5 seconds, other settings on request. Toggle switch on board.			
TEMPERATURE OUTPUT	0.1°C/mV (single-ended), -40° to +100°C, $\pm 0.75^\circ\text{C}$ accuracy, 0°C = 0 mV			
OUTPUT IMPEDANCE	270 ohms, short circuit and surge protected			
POWER REQUIREMENTS	± 11 to ± 15 VDC @ +11 and -6 mA typical; 250 mV peak-to-peak ripple max.; reverse polarity protected			
CONNECTIONS	Sensor: Gold-plated 100 mil header pins; Power & Signal: 3 ft (0.8 m) pigtail, tinned ends			
ENVIRONMENTAL	-25° to +70°C operational, -30° to +100°C storage; 0 to 90% humidity, noncondensing			
MATERIALS	Fiberglass printed circuit board with thru-hole soldered components			
SIZE & WEIGHT	3.85-inch (98 mm) diameter round board, 1.12 inches (28 mm) high at switches; 30 g			

* 1 degree = 3600 arc seconds = 17453 μ radians (microradians) † Single-ended outputs; divide by 2 for differential scale factors.

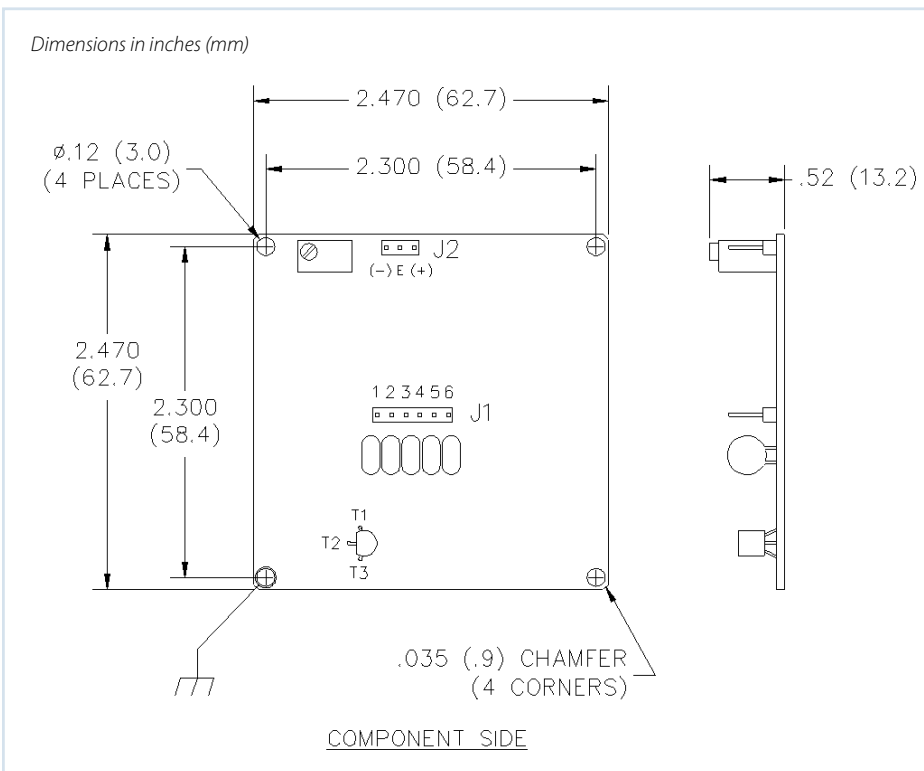

J1 PIN #	FUNCTION
1	8-18 VDC
2	Signal Ground
3	Power Ground
4	+ Tilt
5	- Tilt
6	Temperature

USEFUL ACCESSORIES:

Model 84800	Single-Channel Signal Conditioning Card
P/N 70308	Sensor hook-up cable, specify length
P/N 70304	Additional power & signal cable, specify length

APPLIED GEOMECHANICS

140 Chestnut St.
San Francisco CA, 94111
T: 1+415-364-3200
F: 1+415-861-1448
Geomechanics.com

A CARBO Company

©2009 Applied Geomechanics, Inc. All Rights Reserved. 09.09/X

