

700 SERIES

Platform and Surface Mount Tiltmeters



140 Chestnut Street
San Francisco, CA 94111
Phone: 415-364-3200
Fax: 415-861-1448
www.geomechanics.com
sales@geomechanics.com

Copyright ©2011 by Applied Geomechanics Inc. All rights reserved.
Manual No. B-88-1016, Rev. F

TABLE OF CONTENTS

1	General Information	1
1.1	<i>Introduction</i>	1
1.2	<i>Technical Features</i>	6
1.3	<i>Specifications</i>	6
2	Installation	7
2.1	<i>Initial Check-Out Procedures</i>	7
2.2	<i>Installing Platform Tiltmeters</i>	11
2.3	<i>Installing Surface Mount Tiltmeters</i>	11
3	Recording Tiltmeter Data with External Recorders	12
4	Grounding and Transient Protection	12
5	Converting Readings to Tilt Angles and Temperatures	12
6	Maintenance and Troubleshooting	13
6.1	<i>Introduction</i>	13
6.2	<i>Routine Maintenance</i>	14
6.3	<i>Determining the Cause of Malfunctions</i>	14
A	Warranty and Assistance	A1
B	Custom Specifications for Your 700-Series Tiltmeter	B1
C	Guidelines for Installing Surface Mount Tiltmeters	C1
D	Angle Conversion Chart	D1

TABLE OF FIGURES

Figure 1.	Platform Tiltmeter, Model 701-2.	2
Figure 2.	Floor Mount Tiltmeter, Model 711-2.	3
Figure 3.	Platform Tiltmeter, Model 702.	4
Figure 4.	Floor Mount Tiltmeter, Model 712.	5
Figure 5a.	Platform and Floor Mount Tiltmeter Sign Convention	9
Figure 5b.	Wall Mount Tiltmeter in Installed Position.....	10
Figure 6.	Earth ground circuit.....	13
Figure 7.	Model 83162 Dual-Channel Signal Conditioning Card	16
Figure 8:	Installing 700-Series Tiltmeters	B1

1 General Information

1.1 Introduction

700-Series Platform and Surface Mount Tiltmeters are dual-axis, analog output tiltmeters, designed for high-sensitivity, low power consumption, durability, and reliability under rugged field conditions. Suitable for geotechnical and geophysical projects in remote locations, they will also provide years of trouble-free service in industrial and laboratory applications. They are used worldwide for monitoring earth and structural deformation at dam sites, mines, volcanoes, power plants, engineering and scientific laboratories, bridges, highways, and many other industrial and scientific facilities.

Platform and surface mount tiltmeters are essentially the same and consist of an aluminum or stainless steel base plate, aluminum or stainless steel cover (dome), sensors, PC board, connectors, and switches. They differ in that platform tiltmeters (Figure 1) have adjustable legs that are used for leveling the tiltmeters on any hard horizontal surface. In contrast, surface mount tiltmeters (Figure 2) have holes in the base plate and are mounted over threaded studs embedded in the measurement surface. Nuts are used to adjust the position of surface mount tiltmeters and to stably lock the tiltmeter in place for long-term measurements.

Applied Geomechanics platform tiltmeters are designated by model numbers 701 and 702, which represent the aluminum (Figure 1) and stainless steel versions, respectively. Surface mount tiltmeters are available in floor mount (Models 711 and 712), wall mount (Models 716 and 717) and ceiling mount (Models 714 and 715) versions. In the preceding pairs of model numbers, the first number is an aluminum tiltmeter and the second is a stainless steel tiltmeter. Models 711, 702 and 712 are shown in Figure 2, 3 and 4. By using a Model 719 Universal Mounting Bracket, the same surface mount tiltmeter can be installed on the floor, wall or ceiling. This mounting bracket will also attach a standard platform tiltmeter to any vertical surface.

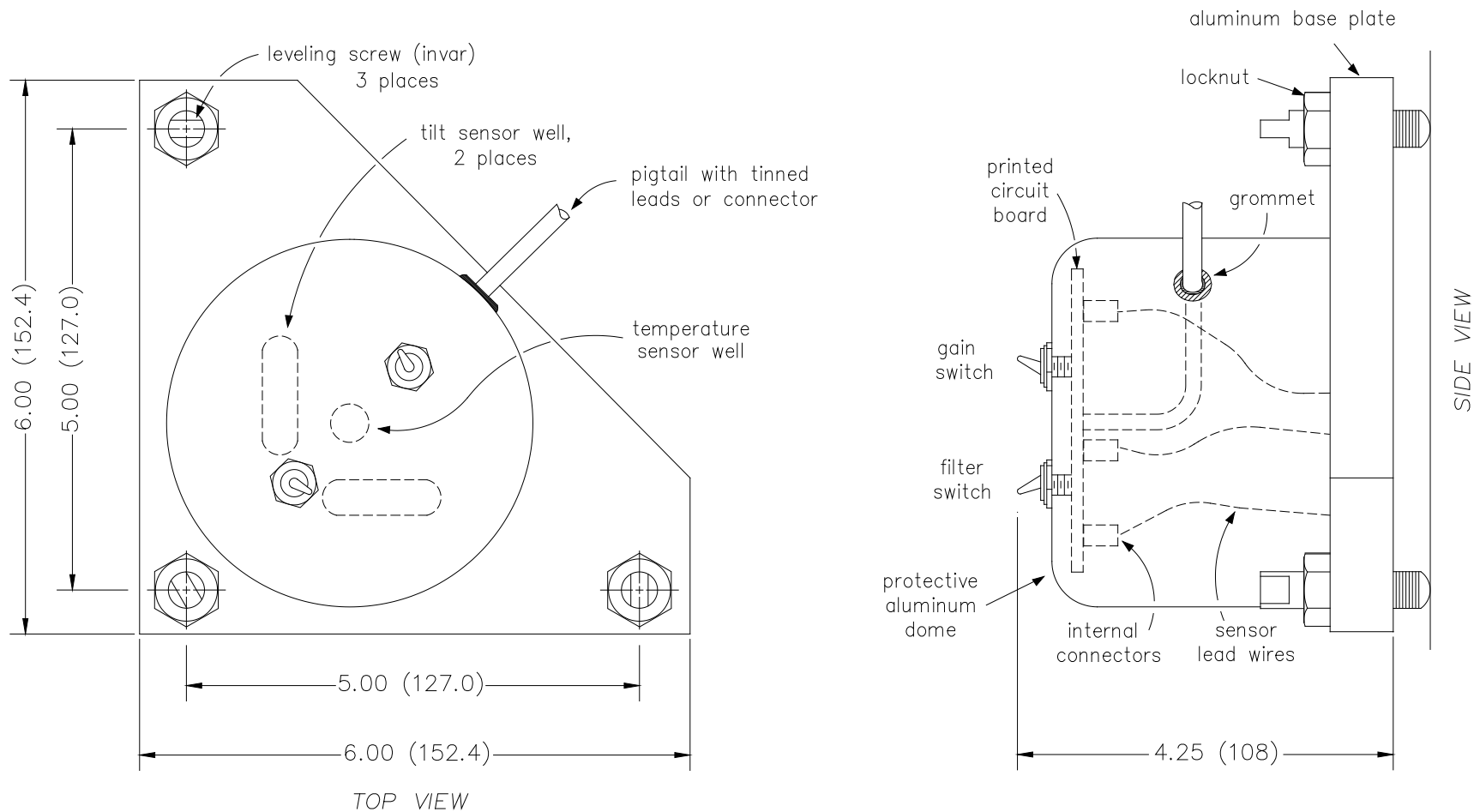

D-87-1112A.DWG

DIMENSIONS ARE IN INCHES (mm)

Figure 1. Platform Tiltmeter, Model 701-2.

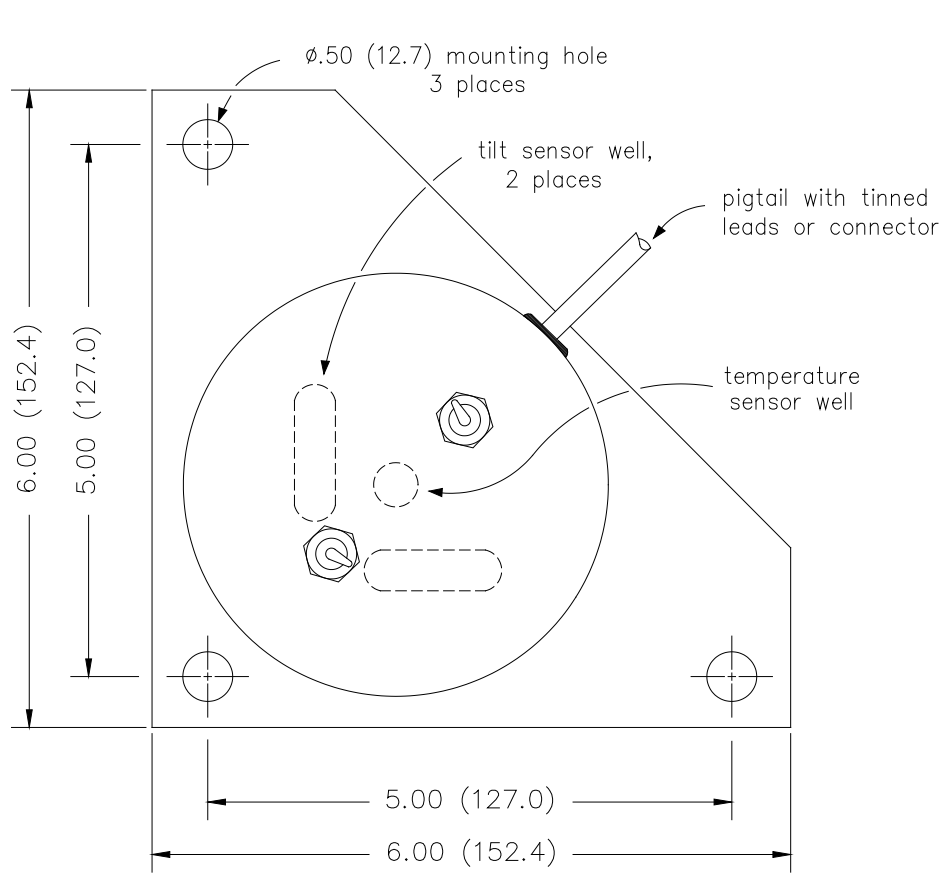

TOP VIEW

D-87-1124B.DWG

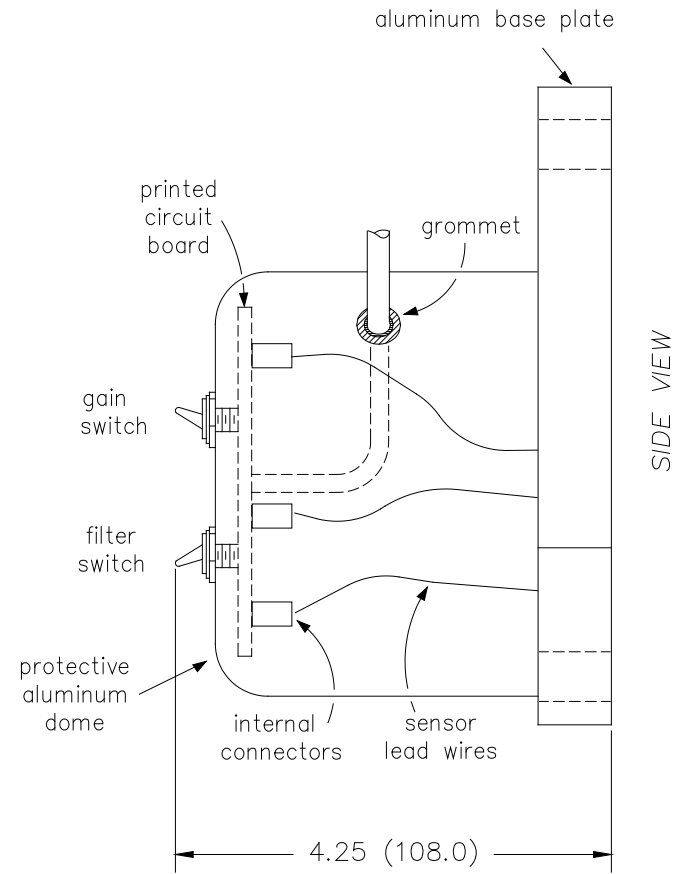

DIMENSIONS ARE IN INCHES (mm)

Figure 2. Floor Mount Tiltmeter, Model 711-2.

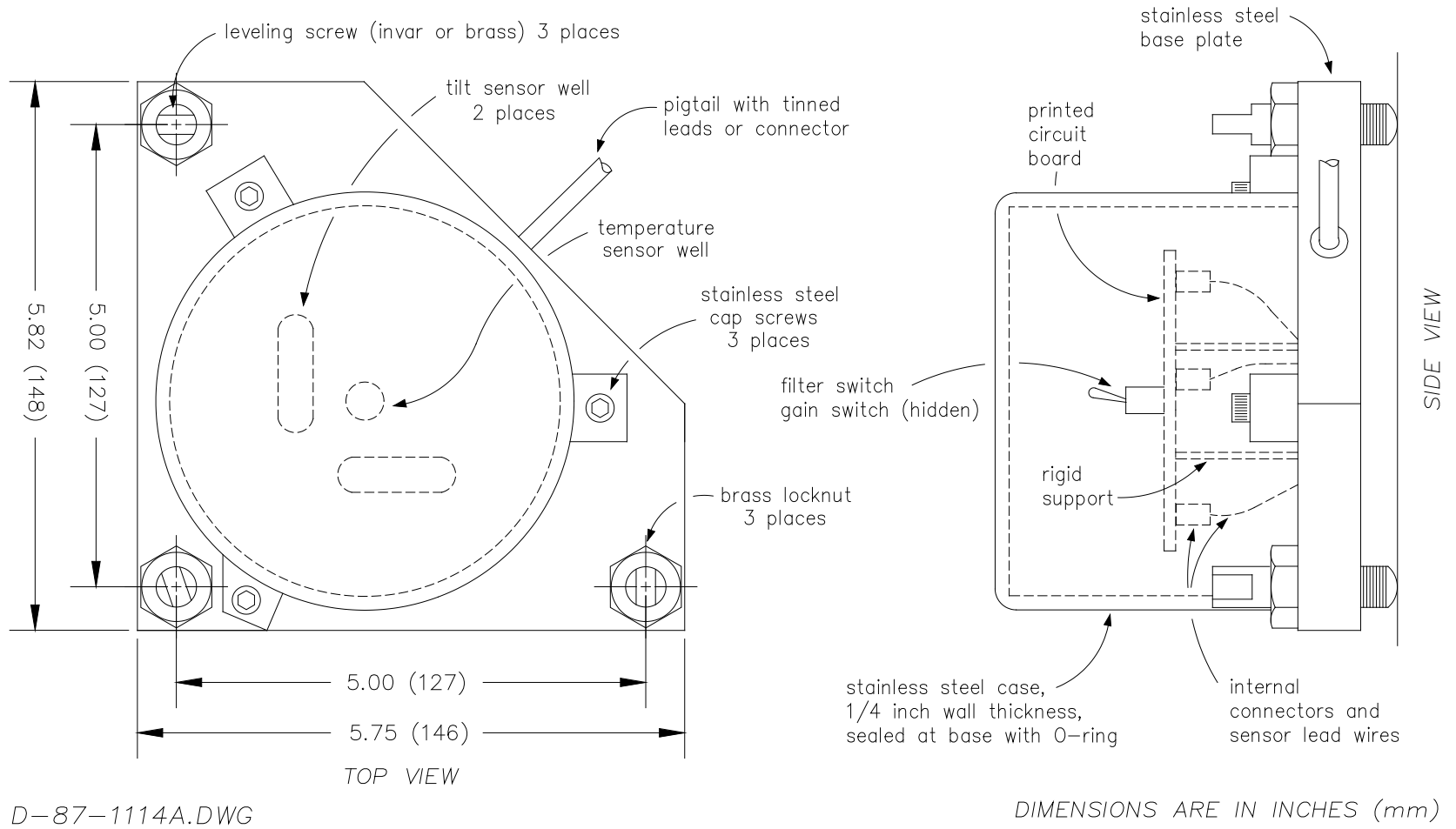
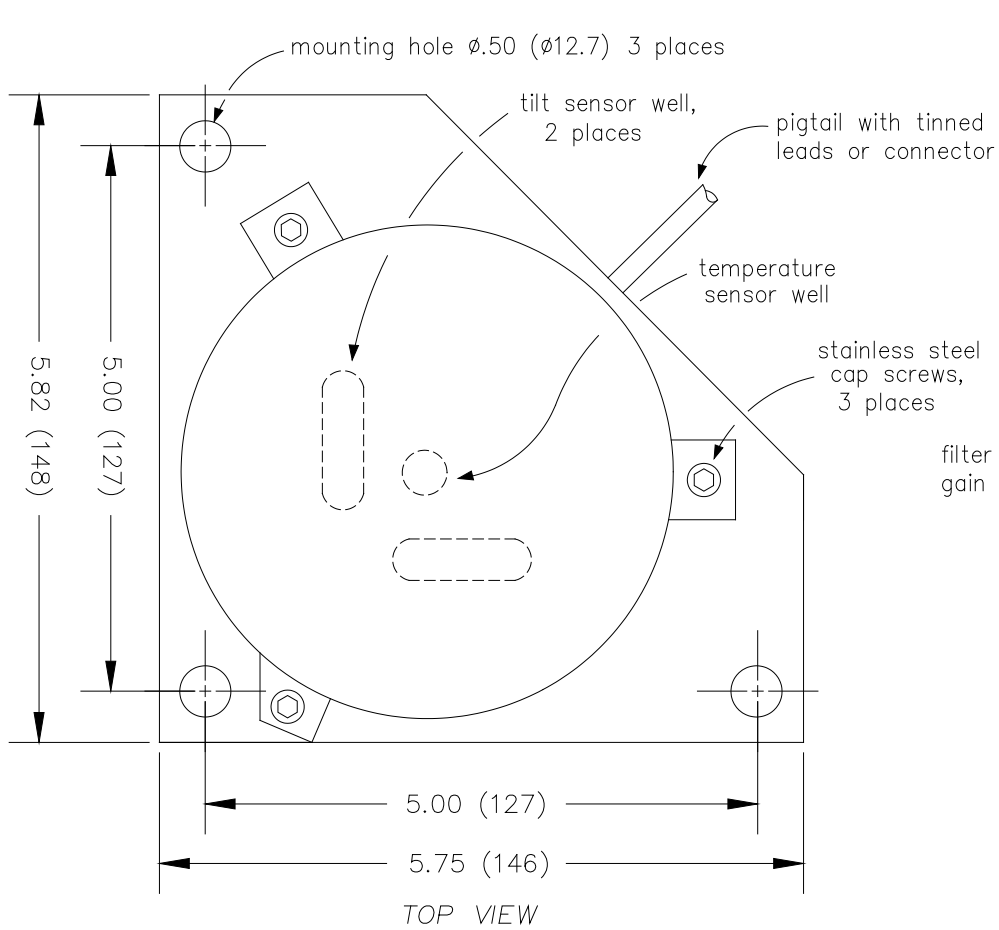
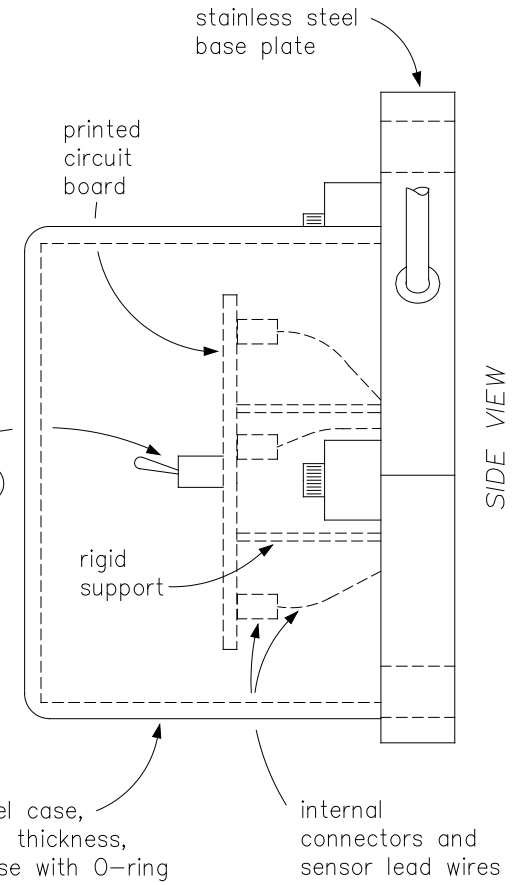

Figure 3. Platform Tiltmeter, Model 702.



D-87-1127A.DWG



DIMENSIONS ARE IN INCHES (mm)

Figure 4. Floor Mount Tiltmeter, Model 712.

1.2 Technical Features

Platform and surface mount tiltmeter models share these technical features:

- They sense a change in tilt angle with an electrolytic sensor, similar to a spirit level.
- All electronics reside on a single internal printed-circuit board.
- All circuit board external connections are gold-plated for long life and noise-free operation.
- All resistors are premium quality, 1% tolerance, metal-film type.
- All tiltmeters are hand-assembled, calibrated, and tested at our plant under stringent quality control standards.
- AGI maintains complete specifications and test records of every tiltmeter built.

Both platform and surface mount tiltmeters function the same: they contain one or two electrolytic level sensors (one for each tilt axis) that produce changes in resistance in response to a rotation of the sensor. Using a balanced bridge or voltage divider network to sense the resistance change, the tiltmeter electronics amplify, actively rectify and filter the AC sensor output to form a high-level DC signal that is proportional to the tilt angle. This DC signal can be read by strip chart recorders, digital voltmeters, analog-to-digital converters or any other standard recording device.

Biaxial tiltmeters contain two orthogonal tilt sensors. The vector sum of the outputs of both channels yields the direction and magnitude of rotation with respect to the vertical gravity vector. 700-Series platform and surface mount tiltmeters also contain a temperature sensor that is installed in the base plate beside the tilt sensors. This temperature sensor allows you to record and evaluate the effects of temperature changes on measured structural and ground behavior.

1.3 Specifications

General specifications for 700-Series platform and surface mount tiltmeters are listed below. Appendix B contains custom specifications for your equipment.

	High-Gain Version	Mid-Range Version	Wide-Angle Version
ANGULAR RANGE Low-Gain Setting: High-Gain Setting:	$\pm 8000 \mu\text{radians}^*$ (± 0.46 degree) $\pm 800 \mu\text{radians}$ (± 0.046 degree)	± 8 degrees ± 0.8 degree	60 degrees ± 8 degrees
SCALE FACTOR†	1 $\mu\text{radian/mV}$	1 degree/Volt	10 degrees/Volt
RESOLUTION	0.1 μradian	1 μradian	2 arc seconds
REPEATABILITY	1 μradian (static)	2 $\mu\text{radians}$ (static)	4 arc seconds (static)
LINEARITY	2% of full span	1.5% of full span	4% of full span, 1% of half span
TIME CONSTANT	0.5 second	0.4 second	0.2 second
TEMPERATURE COEF.	Scale factor: $K_S = +0.05\%/^{\circ}\text{C}$ typ. Zero shift: $K_Z = \pm 3 \mu\text{radians}/^{\circ}\text{C}$ typ.	$K_S = +0.05\%/^{\circ}\text{C}$ typical $K_Z = \pm 0.001$ degree/ $^{\circ}\text{C}$ typical	$K_S = +0.13\%/^{\circ}\text{C}$ typical $K_Z = \pm 0.004$ degree/ $^{\circ}\text{C}$ typical
TILT OUTPUT	Each axis: ± 8 Volts DC (single-ended) and ± 16 Volts DC (differential)		

TEMPERATURE OUTPUT	0.1°C/mV (single-ended), -40° to +100°C, ±0.75°C accuracy, 0°C = 0 mV
OUTPUT IMPEDANCE	270 Ohms, short circuit and surge protected
POWER REQ'TS.	±11 to ±15 VDC @ +11 and -6 mA, 250 mV peak-to-peak ripple maximum, reverse polarity protected
ENVIRONMENTAL	-25° to +70° C operation, -30° to +100° C storage; Rated NEMA 4X (IP65) for continuous operation at 100% humidity, Withstands exposure to rainfall and spray
MOUNTING	Three 0.5-inch (12.7 mm) mounting holes; tiltmeter fastens to stainless steel mounting studs (included)
MATERIALS	Anodized and painted aluminum
CABLE	3m (10 ft) multiconductor cable + overall shield, PVC jacket, connectors included
SIZE & WEIGHT	Varies, but generally 152 x 152 x 102 mm (6 x 6 x 4 inches), 1.4 kg (3 lb)

* 1 degree = 3600 arc seconds = 17453 μradians (microradians)
† Single-ended outputs; divide by 2 for differential scale factors.

Aluminum tiltmeters are protected from light rain and splashes in the field by their domes and seals. However, they are not waterproof and may leak if submerged or exposed to heavy rainfall. If used in wet climates or conditions, they should be protected by a suitable housing or cover. **WATER DAMAGE TO THE TILTMETER ELECTRONICS VOIDS THE WARRANTY!**

2 Installation

2.1 Initial Check-Out Procedures

Before installing any of the tiltmeters, verify that the tiltmeters are functioning properly by following the steps below. The steps are listed using an Applied Geomechanics Model 771 Digital Readout Unit (DRU). You may also elect to use a Model 772 Power Supply/Readout/Interface (PSRI) unit, oscilloscope, or batteries and voltmeters. Be advised that although an oscilloscope or batteries and voltmeters will perform the task, these devices cannot match the speed and convenience you'll get using either the DRU or PSRI.

The GAIN and FILTER switches referred to below are on the outside of aluminum tiltmeters. In the stainless steel models they are inside of the tiltmeter dome. To access the switches on the stainless steel tiltmeters, remove the three bolts that connect the dome to the base plate, then remove the dome. The two sides of the FILTER switch are marked "on" and "off," which correspond to the ON and OFF filter positions. The two sides of the GAIN switch are marked "H" and "L," which correspond to the HIGH and LOW gain positions. If you have a stainless steel tiltmeter, leave the dome off during the following check-out and installation procedures.

1. Set the GAIN switch on the top to the tiltmeter to LOW.
2. Set the FILTER switch on the top of the tiltmeter to OFF.
3. Connect the tiltmeter to the DRU.
4. Turn on the DRU.
5. Refer to the sign convention in Figure 5. Now, holding the tiltmeter in your hands, tilt it in the positive and negative X and Y directions to verify the sign (polarity) of the outputs.
6. Check that the tiltmeter voltage output moves through its full range for both the X and Y axes.
7. Read the temperature sensor output to verify that the temperature sensor is working properly.

Temperature sensor calibration is given in Appendix B.

During the installation of the tiltmeter (see instructions in the next two sections) perform the following gain and filter checks:

1. Verify that the FILTER switch is operating by observing the instrument outputs with the FILTER first in the OFF position, and then in the ON position. When the tiltmeter is moved very slightly with the filter off, the output should respond immediately. With the filter on, the response should be more gradual.
2. Turn the FILTER switch to the OFF position. Next, keep the tiltmeter stationary so that the output stays at one value within its operating range. Change the GAIN switch from HIGH to LOW. The outputs of both channels should drop approximately by the ratio between your high- and low-gain scale factors, given in Appendix B. This behavior verifies that the gain switch is working properly.

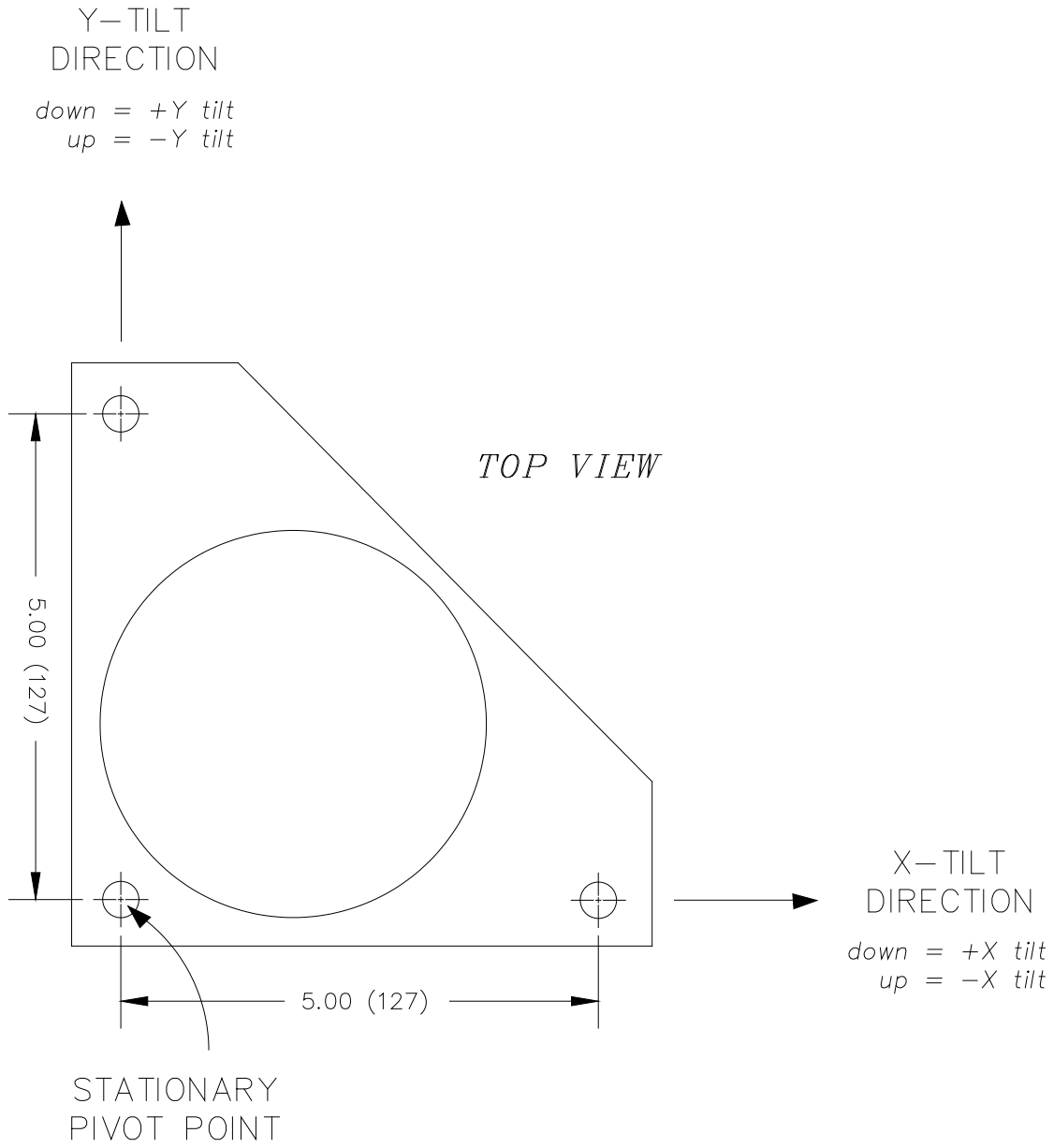

D-87-1128A.DWG

DIMENSIONS ARE IN INCHES (mm)

Figure 5a. Platform and Floor Mount Tiltmeter Sign Convention

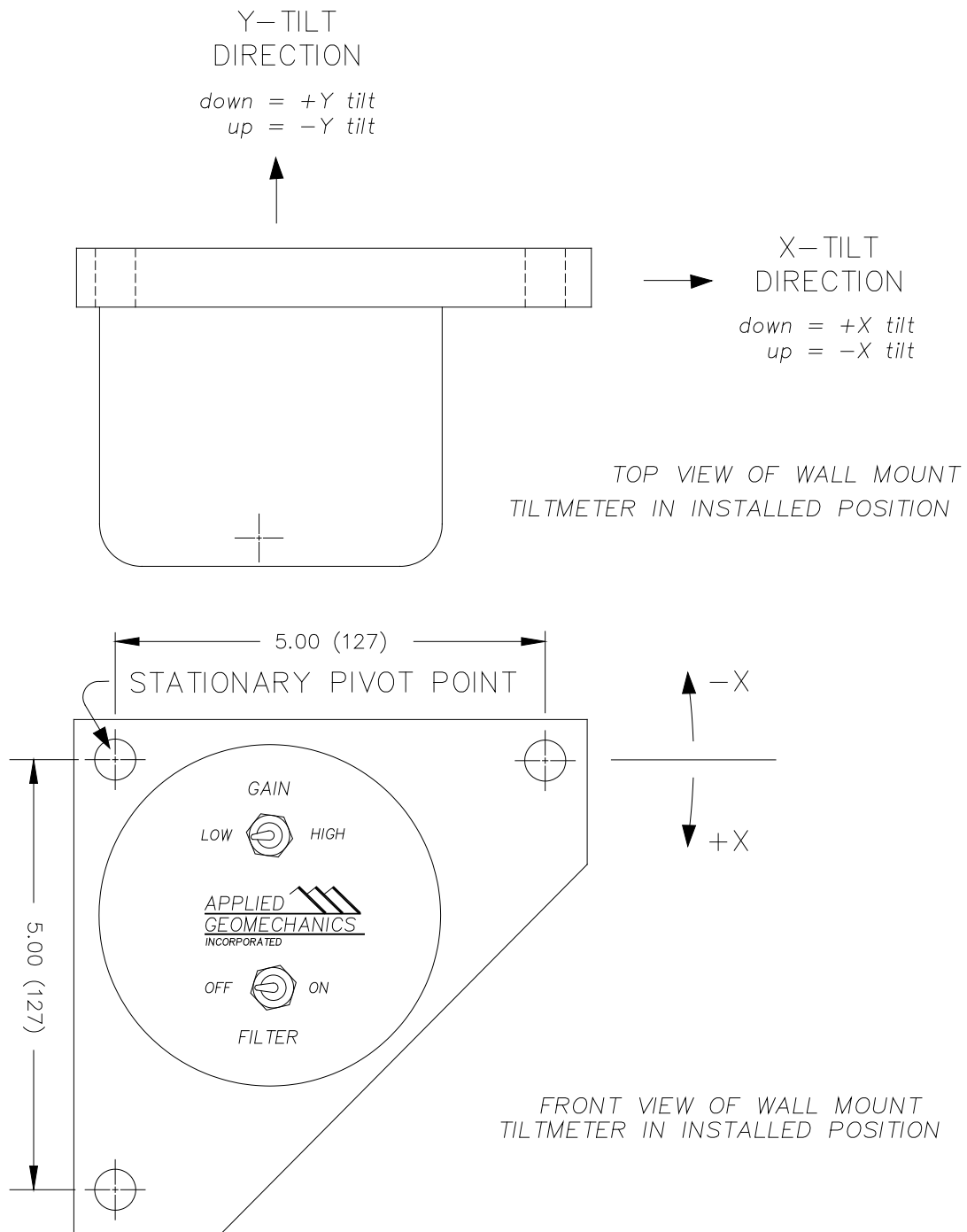

D-87-1129A.DWG

DIMENSIONS ARE IN INCHES (mm)

Figure 5b. Wall Mount Tiltmeter in Installed Position

2.2 Installing Platform Tiltmeters

700-Series platform tiltmeters are built on a triangular aluminum or stainless steel base. This base has three finely threaded invar legs. Install platform tiltmeters on a hard, clean, and smooth horizontal surface, such as ceramic tile, a concrete floor, or a smooth rock. Careful surface preparation is important in achieving stable, low-noise measurements. Every site has different installation requirements. You may wish to consult with an Applied Geomechanics engineer concerning the optimum site preparation for your particular project.

A small bullseye or carpenter's level can be used to perform a rough initial leveling of the tiltmeter. The final leveling should be performed by connecting the tiltmeter to an AGI Model 771 Digital Readout Unit or batteries and two digital voltmeters. To perform the final leveling, turn the FILTER switch to OFF and the GAIN switch to LOW. Next, adjust the threaded legs by turning them slowly in sequence while observing the readout to obtain level (readings of approximately zero volts on both X and Y axes). It is generally a good idea to install the tiltmeter at the middle of its sensing range, *i.e.*, with the output nulled on both channels, so that you will have the maximum dynamic range available for subsequent operational readings.

If you intend to operate the tiltmeter in high gain, turn the GAIN switch to HIGH after you have leveled the tiltmeter in low gain. Continue the leveling procedure until the X and Y outputs are as close to zero as possible. Now, turn the filter on if you want low-pass-filtered data. Carefully replace the dome if you are using a stainless steel tiltmeter. When you have completed these adjustments, hand-tighten the locking nut on each leg, and reconfirm that both channels are still in the middle of their sensing range.

2.3 Installing Surface Mount Tiltmeters

The surface mount tiltmeters are designed to be mounted on bolts or studs, previously anchored or cemented into a solid surface. The bolts should be 1/4" to 3/8" (6 to 9 mm) in diameter and extend at least 2" (5.1 cm) above the surface to which the tiltmeter is to be mounted.

First, thread a nut onto each stud, positioning it close to the surface. Place a flat washer above each nut. Then place the tiltmeter over the studs, followed by another washer and finally another nut threaded on top of each stud. A small bullseye or carpenter's level can be used to roughly level the tiltmeter at this time.

The final leveling should be performed by connecting the tiltmeter to an AGI Model 771 Digital Readout Unit, or batteries and two digital voltmeters. To perform the final leveling, turn the FILTER switch to OFF and the GAIN switch to LOW. Next, adjust the mounting nuts slowly in sequence while observing the readout to obtain level (readings of approximately zero volts on both the X and Y channels). It is generally a good idea to install the tiltmeter at the middle of its sensing range, *i.e.*, with the output nulled on both channels, so that you will have the maximum dynamic range available for subsequent operational readings.

If you intend to operate the tiltmeter in high gain, turn the GAIN switch to HIGH after you have leveled the tiltmeter in low gain. Continue the leveling procedure until the X and Y outputs are as close to zero as possible. Now, turn the filter on if you want low-pass-filtered data. Carefully replace the dome if you are using a stainless steel tiltmeter. When you have completed the adjustments, carefully tighten the top nut on each bolt, and reconfirm that both axes still show approximately zero volts output.

3 Recording Tiltmeter Data with External Recorders

The low-impedance analog output of your tiltmeter is readily measured by a variety of external devices, including digital voltmeters, oscilloscopes and digital data loggers. Refer to “Connector Pin Assignments and Cable Color Coding” in Appendix B for the information you’ll need to connect the tiltmeters to your recording device.

4 Grounding and Transient Protection

Your tiltmeter has a common power and signal ground on its internal circuit board. However, there are separate signal and power ground pins in the tiltmeter connector and separate signal and power ground wires in the tiltmeter cable (Appendix B). In general, the single-ended X, Y, and temperature outputs should be referenced to signal ground at the location where you are reading the data. Because current flows in the power ground wire and because the wire has some resistance, Ohm’s law indicates that the potential at opposite ends of this wire will be slightly different. Thus, signals measured at opposite ends of your cable will be different when power ground is used as the reference. No current flows in the signal ground wire, so the potential in this wire is the same at both ends.

Your tiltmeter has an earth ground circuit that provides protection from high-voltage surges caused by nearby lightning strikes, unstable power sources and other transients carried on your signal/power cable. High-voltage transients are the most common cause of failure of geotechnical field instruments. In a typical occurrence, a high-voltage transient from a lightning strike travels along the cable until it encounters the instrument’s electronic circuitry, where the delicate, low-voltage components are overloaded and fail. To help avoid such an occurrence, each tiltmeter input and output circuit is connected to the tiltmeter case through variable resistance type surge absorbers (Figure 6). To activate this surge protection, connect the tiltmeter base plate to earth (e.g. a water pipe or grounding rod). Make this connection at the grounding screw in the base plate (Models 701, 711, 714 and 716) or at one of the screws holding the dome to the base plate (Models 702, 712, 715 and 717).

Transient protection and noise reduction can also be enhanced by earthing the shield (drain wire) of the tiltmeter cable at one end only.

5 Converting Readings to Tilt Angles and Temperatures

The tiltmeter voltage outputs are quickly converted to tilt angles as follows:

1. Check the scale factor units given in Appendix B.
2. If the scale factor units are “angle/volt” or “angle/mV,” multiply the voltage reading of the tiltmeter by the scale factor to obtain the tilt angle. For example, if the scale factor is $0.1 \mu\text{radian/mV}$ and the voltage reading is $+152 \text{ mV (+0.152 volt)}^1$, then the tilt angle is $+15.2$ microradians from sensor null.
3. If the scale factor units are “volt/angle” or “mV/angle,” divide the voltage reading of the tiltmeter by the scale factor to obtain the tilt angle. For example, if the scale factor is 10 mV/arc second and the voltage reading is $+2077 \text{ mV (+2.077 volts)}$, then the tilt angle is $+207.7$ arc seconds from sensor null.

¹ $\mu\text{radian} = \text{microradian}$; $1 \text{ mV} = 1 \text{ millivolt} = 0.001 \text{ volt}$

The voltage reading from the tiltmeter temperature sensor is similarly converted to temperature using the scale factor supplied in Appendix B. For example, if the scale factor is 0.1 °C/mV and the output voltage is +184 mV (+0.184 volt), then the temperature is +18.4 °C.

6 Maintenance and Troubleshooting

6.1 Introduction

700-Series platform and surface mount tiltmeters are rugged and require no maintenance other than normal cleaning, and occasional lubrication of the adjustable legs on platform tiltmeters. Apart from the procedures described below, the tiltmeters are not field-serviceable. If you encounter problems not described here, please contact Applied Geomechanics Inc. at (831) 462-2801. A service engineer will assist you in determining the cause of any problem.

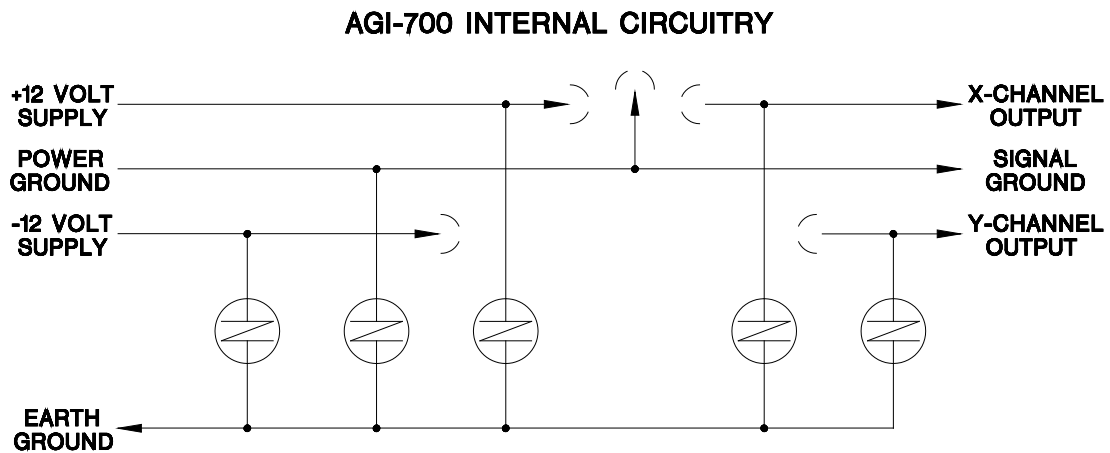

D-88-1020

Figure 2. Earth ground circuit

6.2 Routine Maintenance

Keep all tiltmeters away from extremes of heat and cold. Extreme temperatures shorten the life of the seals and unnecessarily stress the electronic components. Keep tiltmeters out of direct sun because the internal temperature can reach levels considerably greater than the ambient temperature.

Aluminum tiltmeters have been sealed in the factory with silicone rubber cement. This is intended to protect the tiltmeter against splashes or occasional light rainfall. However, aluminum tiltmeters are not fully waterproof and should NEVER BE SUBMERGED in water or any other liquid. WATER DAMAGE TO INTERNAL COMPONENTS VOIDS THE WARRANTY!

In addition to providing a seal, the cement between the dome and the base plate of aluminum tiltmeters provides the mechanical bond between these two parts. In normal use the cement will provide a strong and secure attachment. To maximize the bond life and reduce the possibility of separation, lift the tiltmeter by holding the base plate and not the dome. If the dome should separate from the base plate, it can be reattached by 1. cleaning off the old cement, 2. applying new silicone rubber cement and 3. holding the two sides firmly together until the cement has dried.

In aluminum tiltmeters with an attached cable or pigtail, the internal printed circuit board (PCB) is held in place by nuts in the rubber boots that cover the gain and filter switches. If the rubber boots are ever removed, this should be done WITH THE SWITCHES FACING DOWNWARD to prevent the PCB from falling into the tiltmeter.

Stainless steel tiltmeter models are designed to be fully waterproof to a depth of at least 2 meters (contact factory for depth specifications). To ensure that the O-ring is properly seated so that the seal is maintained, be certain that the screws that secure the dome to the base plate are tight. When the stainless steel dome is removed during tiltmeter installation, make sure that the O-ring and adjacent surfaces are clean when the dome is replaced. A light coating of silicon grease will prolong the life of the rubber O-ring.

6.3 Determining the Cause of Malfunctions

Although the tiltmeters are not field-serviceable, there are some basic things you can do if you should encounter problems. If there is no output when you have connected the tiltmeter to the Model 771 Digital Readout Unit (DRU), Model 772 PSRI, or batteries and voltmeters, first check that the batteries are providing power to the tiltmeter, and that the DRU, PSRI or voltmeter is functioning properly. Then be sure that all connectors are securely attached. Failure to obtain an output signal from the tiltmeter normally is the result of lack of power or a broken wire or connection.

If one or more tiltmeter outputs are firmly “pegged” at either end of the output range, the tiltmeter is probably tilted off scale. If this is not the case, the cause may be a broken connection or short circuit where the sensor lead wires connect to the printed circuit board. The tiltmeter must be opened to correct such a problem.

Aluminum tiltmeters (Models 701, 711, 714 and 716) cannot be opened without special tools. If you have conclusively established that the problem is internal to the tiltmeter, these tiltmeters should be returned to AGI for repair. Internal connections in stainless steel tiltmeters (Models 702, 712, 715 and 717) can be checked by removing the screws that hold down the tiltmeter dome, removing the dome and exposing the internal electronics. If you test for continuity where the power input and signal output wires connect to the printed circuit board (in the center of the board), use the wire colors in Appendix B to identify wire function.

If you remove the small plastic connectors that join the sensor wires to the printed circuit board, be sure to replace the X, Y and temperature connectors exactly as you found them (Figure 7 shows the proper connector locations). **CONNECTING THE X OR Y SENSOR WIRES TO THE TEMPERATURE POSITION ON THE PCB WILL CAUSE PERMANENT TILT SENSOR DAMAGE THAT IS NOT COVERED BY THE WARRANTY.**

If an inspection of the connections to the printed circuit board does not correct the problem, please call an Applied Geomechanics service engineer at (831) 462-2801 for assistance.

CAUTION

NEVER USE AN OHMMETER TO MEASURE THE TILT SENSORS INSIDE THE TILTMETER. APPLYING DC CURRENT THROUGH THE SENSORS WILL CAUSE PERMANENT DAMAGE THAT IS NOT COVERED BY THE WARRANTY.

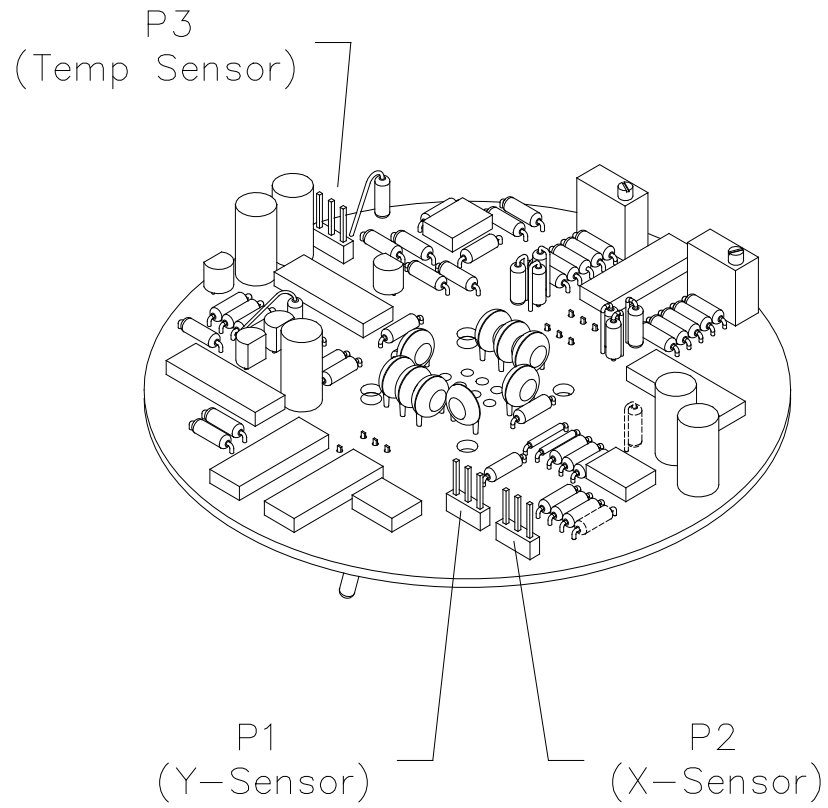

TOP VIEW
(Component Side)

Figure 7. Model 83162 Dual-Channel Signal Conditioning Card

A Warranty and Assistance

Applied Geomechanics tiltmeters and accessories are warranted against defects in materials and workmanship for one year from the date of delivery. We will repair or replace (at our option) products that prove to be defective during the warranty period provided they are returned prepaid to Applied Geomechanics. No other warranty is expressed or implied. The warranty is void if the equipment is operated outside of its specified environmental range, if it is subjected to lightning strikes or power surges, or if it is otherwise abused. After expiration of the warranty, AGI will repair the equipment at its factory for parts and labor charges. Products returned after warranty expiration should be accompanied by a purchase order to cover repair costs. Applied Geomechanics Inc. is not liable for consequential damages.

THE REMEDIES PROVIDED HEREIN ARE THE BUYER'S SOLE AND EXCLUSIVE REMEDIES. AGI SHALL NOT BE LIABLE FOR ANY DIRECT, INDIRECT, SPECIAL, INCIDENTAL OR CONSEQUENTIAL DAMAGES, WHETHER BASED ON CONTRACT, TORT OR ANY OTHER LEGAL THEORY.

B Custom Specifications for Your 700-Series Tiltmeter

Model number: _____

Serial number: _____

Version: High-gain (A) Mid-range (B) Wide-angle (C)

Scale Factors

The output scale factors of your tiltmeter are selected using the GAIN switch on the top of the tiltmeter dome (Models 701-2, 711-2 and 716-2) or inside the dome (Model 712). *Models 701-2(4X) and 711-2(4X) do not have a gain switch, so their scale factor is fixed.* Scale factors are in units of angle/Volt (or angle/mV). The scale factor for differential output is *one half* the scale factor for single-ended output. Differential output is measured between the +X and -X channels and between the +Y and -Y channels, respectively. Single-ended output is measured with reference to signal ground. Scale factors are determined by linear regression with a minimum of 10 steps over the calibration span. Nonlinearity is the maximum deviation from the regression line, divided by the calibration span (± 0.5 degree angular range = 1.0 degree span, etc.). Calibration units are circled in the table below.

Table B1. Calibration data for your tiltmeter

Calibration temperature:	°C			
Scale factor units:	μradian/mV	arc second/mV	arc minute/mV	degree/Volt
Angular range units:	μradians	arc seconds	arc minutes	degrees
The scale factors below are for	single-ended	differential	output.	

	Scale Factor	Max. Nonlinearity	Calibrated over Angular Range of
X, High Gain			±
X, Low Gain			±
Y, High Gain			±
Y, Low Gain			±

Temperature sensor scale factor: 0.1°C/mV (single-ended only). 0 mV = 0°C.

Filters

Your tiltmeter has two single-pole RC low-pass filters (integrators) selected by the FILTER switch on top of the tiltmeter dome or inside the dome (Model 712). Models 701-2(4X) and 711-2(4X) do not have a filter switch and therefore have only one filter time constant.

The time constant (τ) for each filter setting is listed below. After an instantaneous change in tilt, the output signal settles to 90% of its final value after three time constants, and to 98% of this value after four time constants. The corner or cutoff frequency f_c is defined as the frequency at which signal attenuation is 3dB. Filter roll-off above the corner frequency is constant at 6 dB per octave (20 dB per decade). Corner frequency can be calculated as: $f_c = 1/(2\pi\tau)$.

τ values for filter settings:

ON: _____ seconds

OFF: _____ seconds

Output Connector on Tiltmeter Cable

- Bendix PT06A-12-10P (AGI P/N 62302) male plug*
- Tinned Wires (no connector)

Table B2. Connector pin assignments and cable color coding

Bendix Pin #	Wire Color	Signal/Function
H	red	+11 to +15 VDC in
A	black	Power ground
B	violet	-11 to -15 VDC in
G	blue	Channel +Y out
K	brown	Channel -Y out
J	gray	Channel -X out
C	green	Channel +X out
F	-	Cable shield
E	white	Signal ground
D	yellow	Temperature out

Signal and power grounds are common on the tiltmeter electronics circuitry.

* Mating female receptacles are:

- PT02A-12-10S (AGI P/N 62301), panel type, and
- PT01A-12-10S(SR) (AGI P/N 62304), in-line type

C Guidelines for Installing Surface Mount Tiltmeters

These guidelines will help you achieve stable and reliable tiltmeter readings. Applied Geomechanics supplies all of the installation accessories you need for an effective monitoring program.

- Surface mount tiltmeters are typically attached to the measurement surface by mounting studs (threaded rods) fastened or anchored into the surface. Three-point mounting is best because it is the most stable. Single-stud (monopod) mounting is more prone to drift and disturbance. It is not recommended for long-term applications.
- Mounting studs should be as short as possible, of the same length and of the same material for maximum thermal stability. In special cases thermally stable, but more expensive, invar studs can be used.
- Anchoring a mounting stud in a concrete or rock surface is normally done by drilling a hole to a depth of 4-5 cm (1½ - 2 inches), then injecting a small amount of anchoring epoxy. When the stud is inserted into the hole, the epoxy squeezes to the top, surrounding the embedded part of the stud. Lead anchors and expanding anchors can also be used, but only in combination with a mounting plate or bracket that is drawn tight against the surface and cannot shift laterally.

Installation accessories available from Applied Geomechanics include:

Part no. 84410	Mounting Stud Assembly (5/16" – 24 x 4") with nuts and washers, 3 included with each surface mount tiltmeter
Part no. 89026	Anchoring Epoxy Kit (gun, cartridge, 2 nozzles)
Model 718-AL	Mounting Plate (installs tiltmeter on irregular surfaces)
Model 719-AL	Mounting Bracket (see illustration, Figure C1)

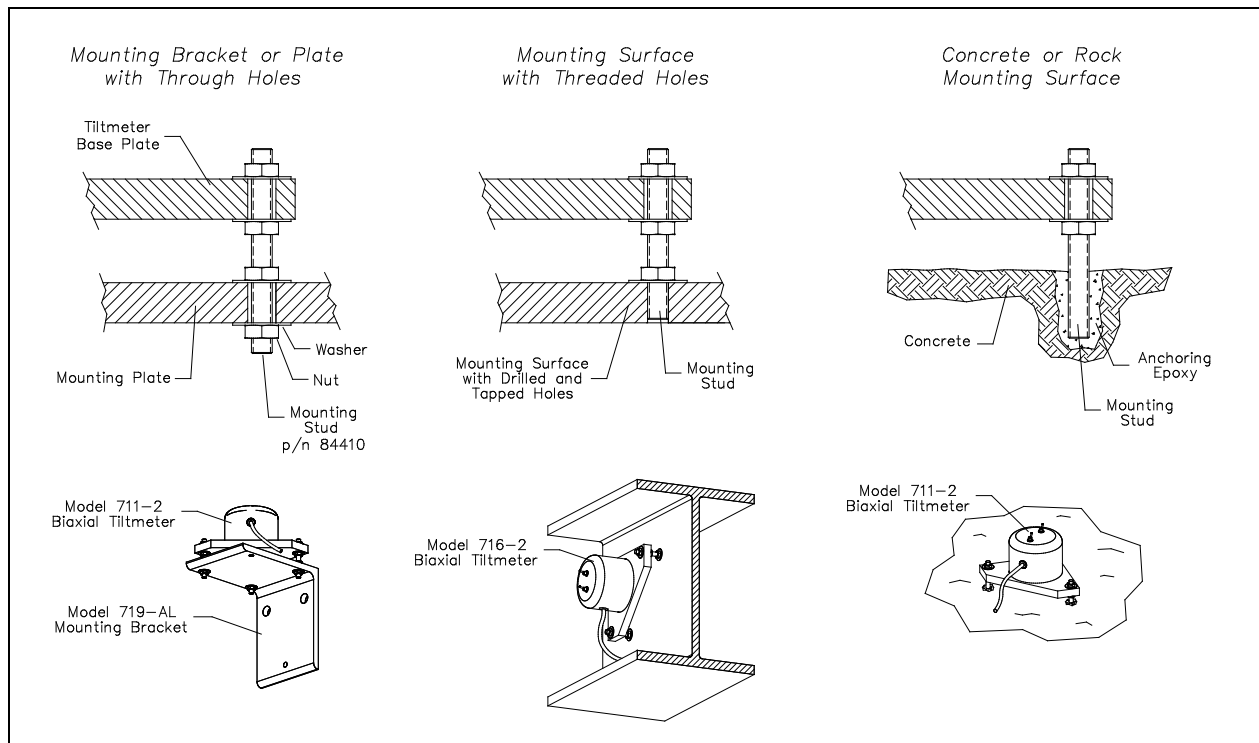

Figure C1. Installing 700-Series Surface Mount Tiltmeters

D Angle Conversion Chart

Table D1. Angle conversion chart

	degrees	arc minutes	arc seconds	μradians	mm/meter	inches/ft
degree =	1	60	3600	17453	17.453	0.2094
arc minute =	0.016667	1	60	290.89	0.29089	3.4907E ⁻³
arc second =	2.7778E ⁻⁴	0.016667	1	4.8481	4.8481E ⁻³	5.8178E ⁻⁵
μradian =	5.7297E ⁻⁵	3.4377E ⁻³	0.20626	1	0.001	1.200E ⁻⁵
mm/meter =	0.057297	3.4377	206.26	1000	1	0.01200