

Guidelines for Installing Tiltmeters in Shallow Boreholes

Tech Note

These guidelines are an overview of typical borehole tiltmeter installation methods. They will help you achieve stable and reliable readings from the Lily Borehole Tiltmeters installed in shallow holes less than about 10m (33 ft) deep. Additional details are found in AGI's tiltmeter user's manuals.

If caving is not a problem, the hole can be left uncased. Otherwise, a driven or cemented casing is recommended. The drawings below illustrate the approximate dimensions of the hole. Hole diameters of 20-30 cm are typical. The greater the diameter, the easier it is to manipulate the tiltmeter in the hole.

Sand is used to couple the tiltmeter to the borehole walls. First, sand is poured into the hole to a depth of several centimeters. The tiltmeter is then lowered into the hole until it rests on the surface

of the sand. More sand is poured into the hole until about half of the tiltmeter is buried; the tiltmeter should stand vertically without support from above. Sand should be compacted into place by tamping the area around the tiltmeter with an appropriate rod or pole. This will ensure good coupling between the tiltmeter enclosure and the surrounding earth. Finally, the full length of the tiltmeter is covered with sand, leaving a stable installation that can be used for months or years.

The Lily Geodetic Borehole Tiltmeter is leveled remotely using internal motors operated by issuing pre-programmed firmware commands with any command prompt emulator. This versatility allows Lily borehole tiltmeters to be installed both in shallow holes and at depths >1000m.

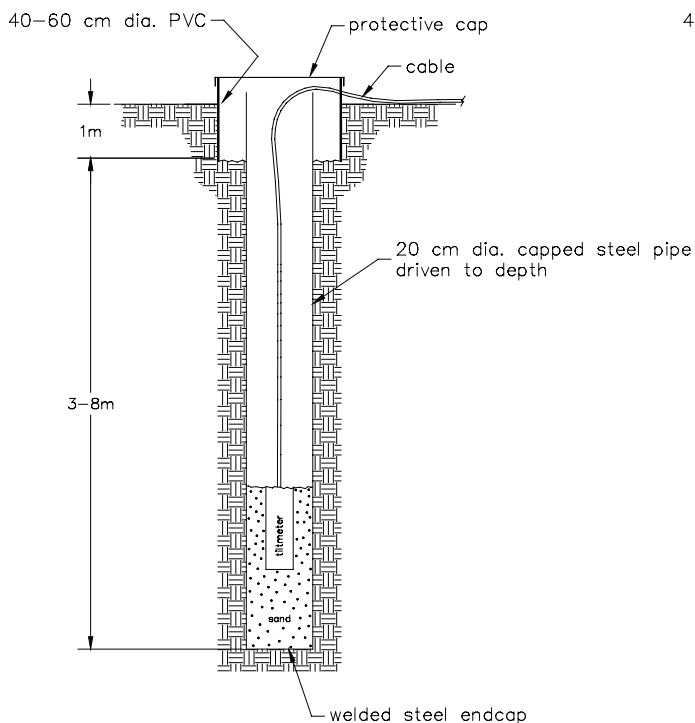

Hole with driven casing

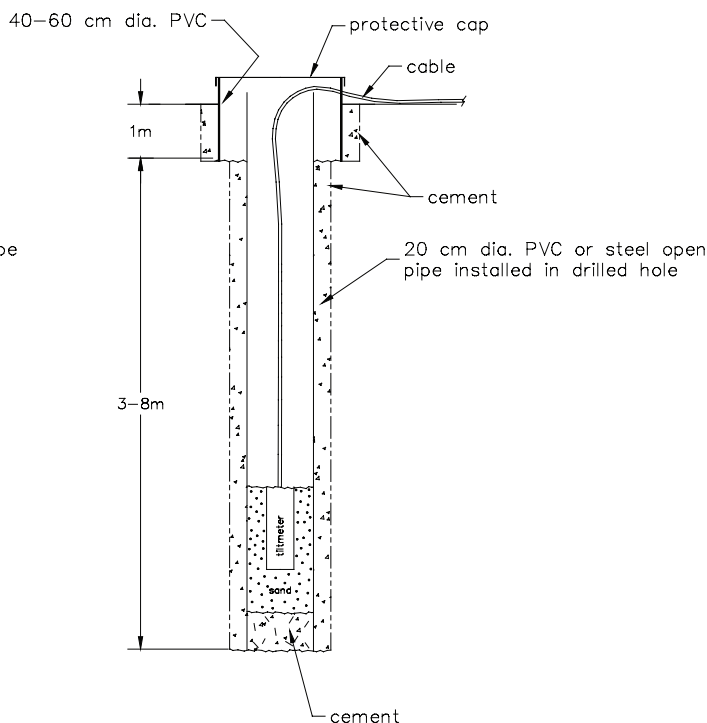

Hole with cemented casing

(Uncased holes may be used if the hole will stay open)