

Model 711-2 Floor & 716-2 Wall Mount Tiltmeter

(Biaxial)

These precision biaxial tiltmeters bolt or clamp to any surface and are well suited for areas of heavy traffic or vibration. They are identical to our popular Model 701-2 Platform Tiltmeter, but have 0.5-inch (12.7-mm) diameter holes in their

three corners instead of adjustable legs. The holes fit over threaded stainless steel studs, provided with each order. The tiltmeter is double-nutted to the studs after they have been firmly anchored in the mounting surface.



PRECISION BIAXIAL TILTMETERS BOLT OR CLAMP TO ANY SURFACE

The internal electronics of Models 711-2 and 716-2 will drive cable lengths of 1000m. These tiltmeters are widely used for structural monitoring, load testing, and precision alignment of antennae and machinery.



Model 711-2 Floor Mount Tiltmeter

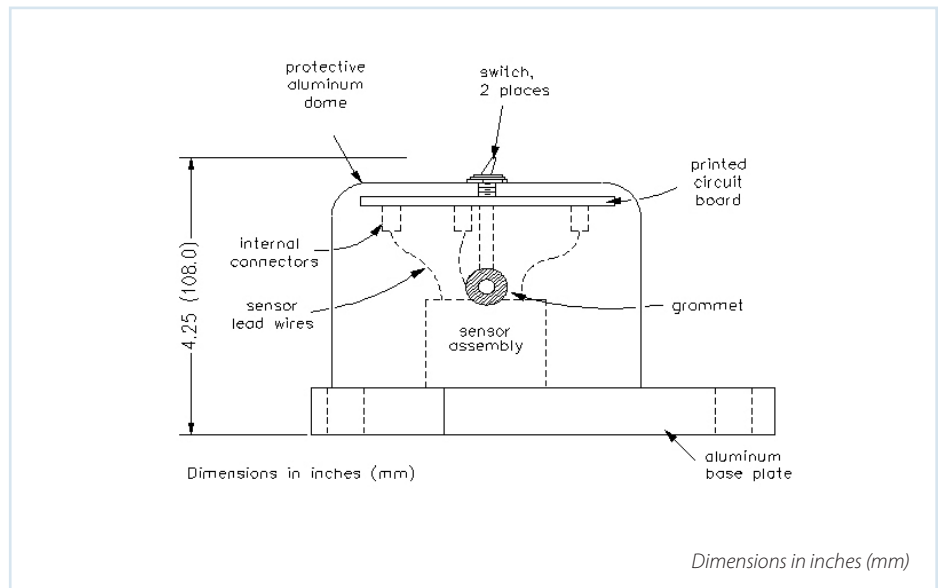

Side View Model 711-2 Floor Mount Tiltmeter

	MODELS 711-2A & 716-2A HIGH-GAIN VERSION	MODELS 711-2B & 716-2B MID-RANGE VERSION	MODELS 711-2C & 716-2C WIDE-ANGLE VERSION
ANGULAR RANGE			
Low-Gain Setting:	±8000 μradians* (±0.46 degree)	±8 degrees	60 degrees
High-Gain Setting:	±800 μradians (±0.046 degree)	±0.8 degree	±8 degrees
SCALE FACTORS			
Low-Gain Setting: †	1 μradian/mV	1 degree/Volt	10 degrees/Volt
High-Gain Setting: †	0.1 μradian/mV	0.1 degree/Volt	1 degree/Volt
RESOLUTION	0.1 μradian	1 μradian	1 arc second
REPEATABILITY	1 μradian (static)	2 μradians (static)	2 arc seconds (static)
LINEARITY	High-gain setting: 0.2% of full span Low-gain setting: 2% of full span	High-gain setting: 0.2% of full span Low-gain setting: 1.5% of full span	High-gain setting: 0.5% of full span Low-gain setting: 2% of full span
TIME CONSTANTS	Filter on: 7.5 sec, Filter off: 0.5 sec	Filter on: 7.5 sec, Filter off: 0.4 sec	Filter on: 7.5 sec, Filter off: 0.1 sec
TEMPERATURE COEF.	Scale factor: KS = +0.05%/°C typ. Zero shift: KZ = ±3 μradians/°C typ.	KS = +0.05%/°C typical KZ = ±0.001 degree/°C typical	KS = +0.13%/°C typical KZ = ±0.004 degree/°C typical
ENVIRONMENTAL	-8° to +70° C operation and storage; -25° C version available	-25° to +70° C operation and storage; 0-90% humidity, noncondensing	-25° to +70° C operation and storage; 0-90% humidity, noncondensing
TILT OUTPUT	Each axis: ±8 Volts DC (single-ended) and ±16 Volts DC (differential)		
TEMPERATURE OUTPUT	0.1°C/mV (single-ended), -40° to +100°C, ±0.75°C accuracy, 0°C = 0 mV		
OUTPUT IMPEDANCE	270 Ohms, short circuit and surge protected		
POWER REQ'TS.	±11 to ±15 VDC @ +11 and -6 mA, 250 mV peak-to-peak ripple maximum, reverse polarity protected		
MOUNTING	Three 0.5-inch (12.7 mm) mounting holes; tiltmeter fastens to stainless steel mounting studs (included)		
MATERIALS	Anodized and painted aluminum		
CABLE	3m (10 ft) multiconductor cable + overall shield, PVC jacket, connectors included		
SIZE & WEIGHT	6 x 6 x 4 inches (15 x 15 x 10 cm), 3 lb (1.4 kg)		

*1 degree = 3600 arc seconds = 17453 μradians (microradians) † Single-ended outputs; divide by 2 for differential scale factors.

Top View Model 711-2 Floor Mount Tiltmeter

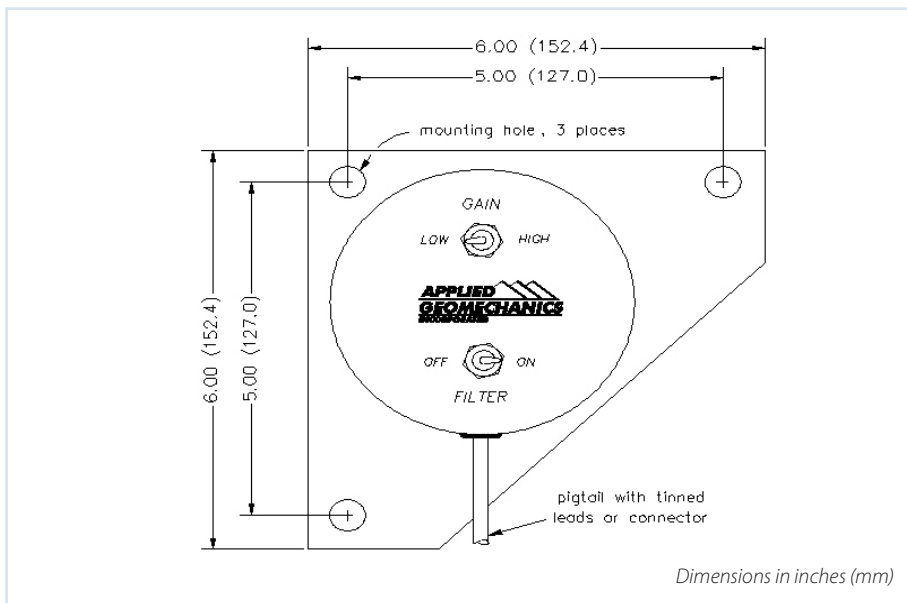

ORDER CODES:

711-2A	Floor Mount, High-Gain Version
711-2B	Floor Mount, Mid-Range Version
	Floor Mount, Wide-Angle Version
716-2A	Wall Mount, High-Gain Version
716-2B	Wall Mount, Mid-Range Version
716-2C	Wide-Angle Version

USEFUL ACCESSORIES:

70304	Additional cable, please specify length
62301	Female panel receptacle (mates to P/N 62302 connector on cable)
62304	Extra female in-line receptacle (one is included with tiltmeter)
718-AL	Mounting plate, 8.5 x 9 in (216 x 229 mm); speeds installation
719-AL	Universal mounting bracket, attaches Model 711-2 to wall or Model 716-2 to floor
84410	Extra mounting stud assembly, specify quantity required
771	Digital Readout Unit

APPLIED GEOMECHANICS, INC.

140 Chestnut St.
San Francisco, CA 94111
T: +1-415-364-3200
F: +1-415-861-1448
geomechanics.com

