

Model A-3, A-4, A-5, A-6

(Rod-Type Borehole Extensometers)

APPLICATIONS

Rod Type Extensometers measure displacement or deformation in soil, rock and concrete structures. Typical applications include the measurement of:

- Ground movements around tunnels
- Deformation of dam abutments and foundations
- Ground movement behind retaining walls, sheet piling, slurry walls, etc.
- Ground movements in the walls of open pit mines
- Deformation of concrete piles (tell-tales)
- Fracturing in the roofs and walls of underground caverns
- Subsidence above tunnels and mine openings
- Settlement and heave of foundations in soft soil



OPERATING PRINCIPLE

Rod Extensometers are usually installed in boreholes with from one to eight borehole anchors. Movement of rods attached to the anchors is measured relative to the head of the extensometer anchored at the mouth of the borehole and can be analyzed to reveal the magnitude of the deformation between the anchors.

Installation is accomplished by assembling the anchors, rods and pipes outside the borehole, placing the assembly in the borehole then fixing the anchors in place. The head of the extensometer can be configured for manual readout using a dial indicator and/or for electronic readout using vibrating wire sensors, linear potentiometers or DCDT's.

Two main types of extensometer heads can be identified. The Flange type is designed to sit on the surface of the rock, soil or concrete structure at the mouth of the bore-hole. The Flangeless type is designed to be recessed into the borehole or into an enlarged section of the borehole; usually to provide protection of the head from traffic, vandalism or from blasting, construction activity, etc.

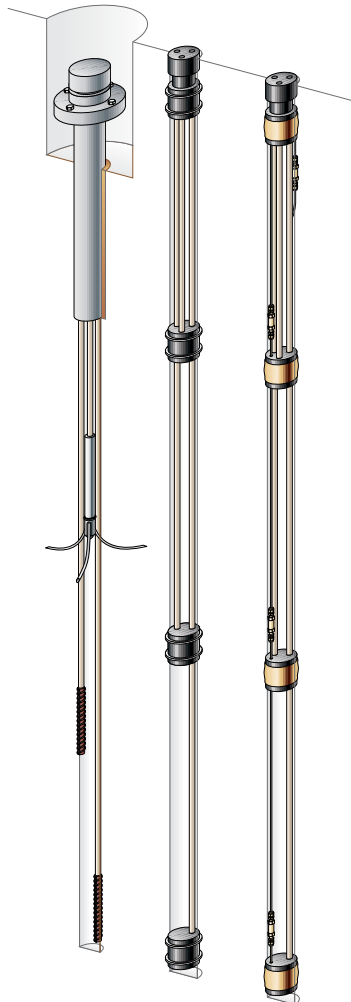

Model A-3, A-4 and A-5 Multiple Point Extensometers (left to right).

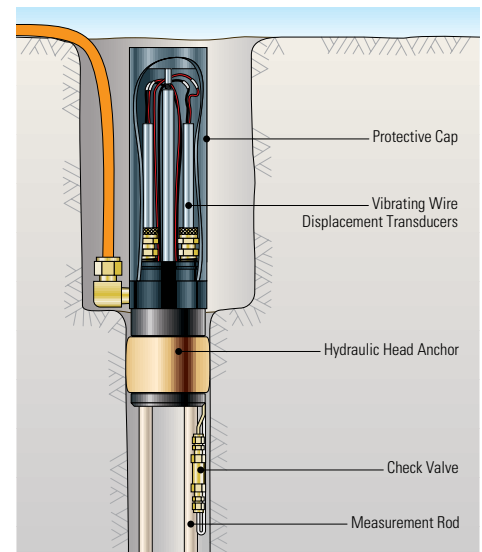

Flangeless type head assembly.

MODEL A-3 MULTIPLE POINT GROUTABLE ANCHOR

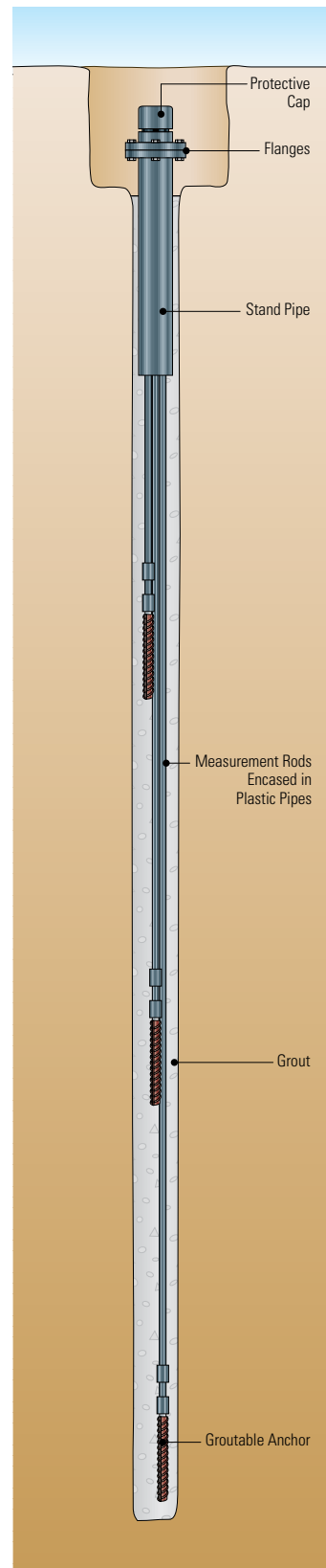

Model A-3 with groutable anchors.



Groutable anchor.

The Model A-3 is the preferred design for installation in downward directed boreholes which are easily filled with cement grout.

The borehole anchors of the Model A-3 are made from lengths of steel reinforcing bars which are connected to the measurement rods. The rods are protected from the grout by plastic pipes to ensure their free travel.

Anchor movements are sensed mechanically using a dial indicator or depth micrometer, or electronically to measure the position of the top of the attached rod relative to a stainless steel reference plate in the head of the instrument. Up to six of these rod / pipe / anchor combinations of differing lengths can be installed in one borehole. This not only enables the measurement of the magnitude of any movements but also the location of any failure planes and zones of movements.

A special bayonet modification to the anchor will allow the measurement rod to be disengaged from the anchor and moved a known distance. With such a feature it is possible to check the correct functioning of the instrument during its working life; this adds to its reliability.

By means of flanges, the head of the extensometer is designed to fit a 3" standpipe that is firmly anchored in the mouth of the borehole at the surface.

MODEL A-4 MULTIPLE POINT SNAP-RING ANCHOR

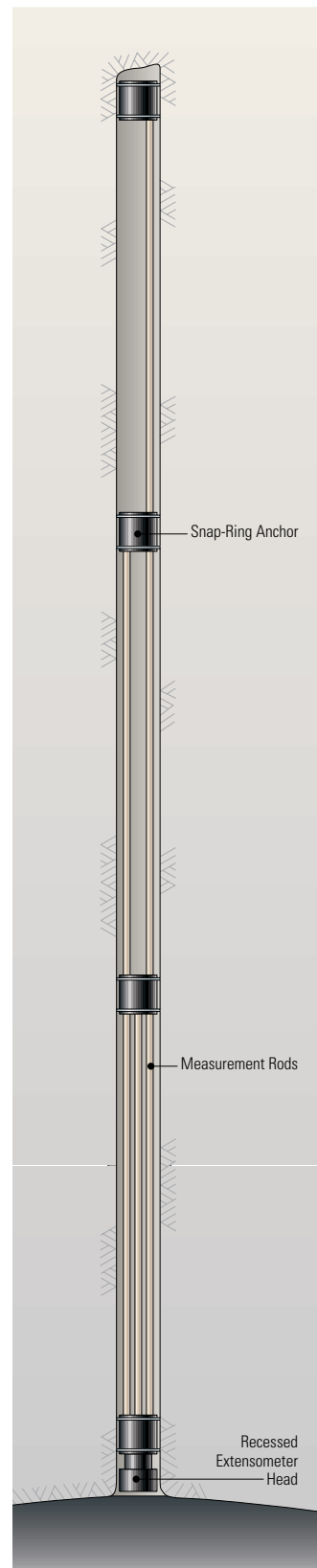

Model A-4 with snap-ring anchors.



Snap-ring type anchor.

The Model A-4 is designed for upward directed boreholes, in hard or competent rock, that are smooth, uniform in diameter and will stay open.

Anchors are easily installed by pushing them to the required depth on the end of the setting rods and then pulling on a cord to remove the locking pin. This allows two retaining rings on each anchor to snap outward and grip the borehole. Up to eight anchors may be installed at various depths in the borehole.

Stainless steel rods from each anchor terminate in machined tips which rest inside the collar anchor. This collar anchor is set inside the mouth of the borehole, again using a snap-ring type anchor. If the mouth of the borehole is enlarged, a collar stabilization tube may be required; it is cemented inside the borehole to provide a good gripping surface for the collar anchor.

The collar anchor has a stainless steel reference plate containing holes through which the stem of a depth micrometer or dial indicator can be inserted to measure the position of the rod tips. Alternatively, the collar anchor can be configured for electronic readout. Intermediate borehole anchors tend to support and space the longer rods, however additional spacers may be installed as required.

MODEL A-5 MULTIPLE POINT HYDRAULIC ANCHOR

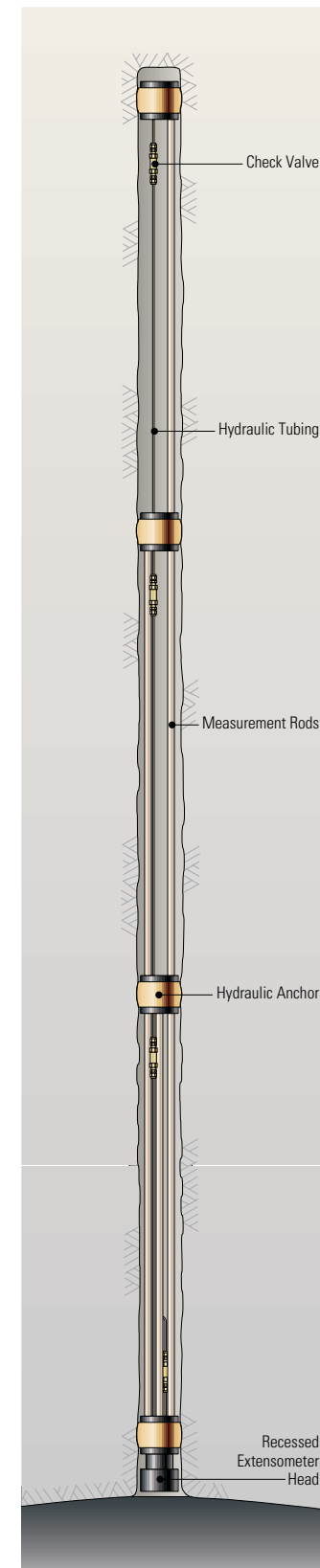

Model A-5 with bladder anchors.



Bladder type hydraulic anchor.

The Model A-5 uses hydraulic borehole anchors and can be easily installed in boreholes oriented in any direction. They are particularly useful in boreholes which are fractured or oriented upwards and which are difficult to grout.

The hydraulic bladder type anchors consist of a spool of high strength plastic around which a sealed, pressure tight soft copper tube is wrapped. Attached to the copper bladder is a high pressure nylon inflation line and check valve. The inflation of the anchors is accomplished with a hydraulic pump which causes the copper bladder to expand and "unwind", filling the space between the spool and the borehole wall. The copper permanently deforms so that the shape does not change and the grip is not lost even if the check valve fails.

The hydraulic bladder type anchors are designed for nominal borehole diameters but can accommodate up to 30 mm of oversize without loss of grip.

Readout is achieved using dial indicators, depth micrometers or electronically.

MODEL A-6 FLEXIBLE ROD TYPE



Model A-6 assembled with groutable anchors and coiled for shipment.

The Model A-6 uses continuous lengths of fiberglass rods (inside protective tubing), cut to customer specified lengths, coiled at the factory and shipped ready for installation. The extensometer is lightweight, making it easier to handle for installation and less costly to ship. On-site assembly time is minimal and the installation procedure is simplified.

The Model A-6 can be supplied with either groutable rebar-type anchors or hydraulic anchors. Where grouting is required, the extensometer can be supplied with a pre-assembled grout tube.

When hydraulic anchors are used, the extensometer is supplied with oil-filled tubes attached.

To install the extensometer, the assembly is uncoiled on the surface and fed into the borehole. The assembly is usually lightweight enough so that this operation can be carried out easily by one person (even for overhead installations). With the extensometer in position, the borehole is either grouted, or the hydraulic anchors actuated (and then grouted, if necessary).

Readout can be either manual, electronic or both.

BORROS TYPE ANCHORS

Borros type anchors are recommended for soft soils where deep penetration of the prongs is required for good anchorage.

With the borros type anchor, hydraulic pressure is applied to extend 3 (single action) or 6 (double action) prongs from the anchor body into the borehole wall. Fully extended, the prongs protrude approximately 150 mm from the anchor body at 3 places, spaced 120° from one another.



Single-action borros anchor before and after prong extension.

This helps to ensure positive, end bearing anchorage as opposed to friction bearing anchorage in the case of the bladder anchor.

ROD TYPES

Extensometer rods are 6 mm in diameter and are available in three different materials. The standard material is 303 stainless steel connected together using flush couplings in 3 meter or shorter lengths. Fiberglass rods may be substituted using continuous lengths as in the Model A6 Extensometer. Carbon composite rods

are recommended where temperature effects need to be reduced to a minimum.

Long rods (i.e. 50 m to 100 m long) can be tensioned by means of springs inside the extensometer head. This has the effect of taking out any slack in the rods and improves the precision of the measurement.

ROD PROPERTIES

MATERIAL	DIAMETER	WEIGHT/METER	YOUNG'S MODULUS	TEMPERATURE COEFFICIENT
303 Stainless Steel	6 mm	0.25 Kg/m	200 GPa	17.5 ppm/°C
Fiberglass	6 mm	0.06 Kg/m	20 GPa	3.0 ppm/°C
Carbon Composite	6 mm	0.05 Kg/m	130 GPa	< 1.0 ppm/°C

¹ Accuracy of ±0.1% available on request.

SENSORS

MODEL 4450 VW DISPLACEMENT TRANSDUCER

The Model 4450 Vibrating Wire Displacement Transducer provides remote readout for Geokon extensometers. They are particularly useful where other types of Vibrating Wire sensors are used and for installations where long cable runs are required.

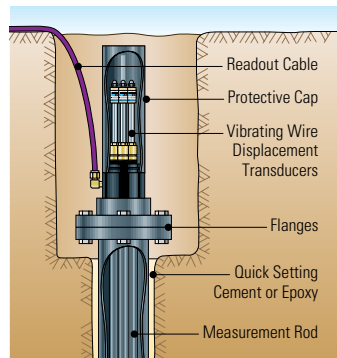

Model 4450 Extensometer Head Assembly with vibrating wire transducers.

TECHNICAL SPECIFICATIONS

Standard Ranges ¹	12.5, 25, 50, 100, 150, 200 mm
Resolutions	0.02% F.S.
Accuracy	±0.25% F.S.
Nonlinearity	< 0.5% F.S.
Temperature Range ²	-20°C to +80°C

¹ Other ranges available on request.

² Other temperature ranges available on request.

APPLIED GEOMECHANICS

140 Chestnut St.
San Francisco CA, 94111
T: 1+415-364-3200
F: 1+415-861-1448
Geomechanics.com

A CARBO Company

©2009 Applied Geomechanics, Inc. All Rights Reserved. 09.09/X

SENSORS (CONTINUED)

MODEL 1500 LINEAR POTENTIOMETER

The Model 1500 Linear Potentiometer utilizes a sturdy 6.5 mm diameter rod which protrudes from both ends as the actuating shaft. This facilitates connection of the linear potentiometer to extensometer rods and also permits a mechanical check on the readings using either a dial indicator or a depth micrometer.



Model 1500 Linear Potentiometer pictured with Model RB-100 Readout Box.

TECHNICAL SPECIFICATIONS

Standard Ranges	50, 100, 150, 250, 610 mm
Least Reading	0.025 mm
Accuracy ¹	±0.25% F.S.
Nonlinearity	< 0.5% F.S.

¹ Accuracy of ±0.1% available on request.

MODEL 1450 DC-DC LVDT

DC-DC LVDT's for dynamic and/or high temperature applications

are also available. Standard ranges are 50 mm, 100 mm and 150 mm. Other ranges available on request.

READOUT INSTRUMENTS

Manual Readout is performed using the Model 1400-1 Dial Indicator (50 mm range) or 1400-4 Digital Depth Micrometer (50-150 mm range).

Electronic readout is achieved using the Model GK-401 or GK-403 VW Readout Box (Model 4450) or the Model RB-100 Linear Potentiometer Readout Box (Model 1500).

For automatic monitoring, readout is best accomplished, using the Geokon Micro-1000 Datalogger, or any other datalogger capable of reading vibrating wire sensors (Campbell Scientific CR10X, Data Electronics Datataker 600, Geomation Model 2380, etc.).



Model 1400-1 Dial Indicator (top) and Model 1400-4 Digital Depth Micrometer.



Geokon Micro-1000 Datalogger.

**APPLIED
GEOMECHANICS**