



The World Leader in Vibrating Wire Technology

*48 Spencer Street
Lebanon, NH 03766, USA
Tel: 603•448•1562
Fax: 603•448•3216
E-mail: geokon@geokon.com
<http://www.geokon.com>*

Instruction Manual

Model 4650

VW Settlement Sensor

No part of this instruction manual may be reproduced, by any means, without the written consent of Geokon, Inc.

The information contained herein is believed to be accurate and reliable. However, Geokon, Inc. assumes no responsibility for errors, omissions or misinterpretation. The information herein is subject to change without notification.

Copyright © 1984, 2003, 2004, 2006, 2008, 2009 by Geokon, Inc.

(Doc Rev K, 04/09)

Warranty Statement

Geokon, Inc. warrants its products to be free of defects in materials and workmanship, under normal use and service for a period of 13 months from date of purchase. If the unit should malfunction, it must be returned to the factory for evaluation, freight prepaid. Upon examination by Geokon, if the unit is found to be defective, it will be repaired or replaced at no charge. However, the WARRANTY is VOID if the unit shows evidence of having been tampered with or shows evidence of being damaged as a result of excessive corrosion or current, heat, moisture or vibration, improper specification, misapplication, misuse or other operating conditions outside of Geokon's control. Components which wear or which are damaged by misuse are not warranted. This includes fuses and batteries.

Geokon manufactures scientific instruments whose misuse is potentially dangerous. The instruments are intended to be installed and used only by qualified personnel. There are no warranties except as stated herein. There are no other warranties, expressed or implied, including but not limited to the implied warranties of merchantability and of fitness for a particular purpose. Geokon, Inc. is not responsible for any damages or losses caused to other equipment, whether direct, indirect, incidental, special or consequential which the purchaser may experience as a result of the installation or use of the product. The buyer's sole remedy for any breach of this agreement by Geokon, Inc. or any breach of any warranty by Geokon, Inc. shall not exceed the purchase price paid by the purchaser to Geokon, Inc. for the unit or units, or equipment directly affected by such breach. Under no circumstances will Geokon reimburse the claimant for loss incurred in removing and/or reinstalling equipment.

Every precaution for accuracy has been taken in the preparation of manuals and/or software, however, Geokon, Inc. neither assumes responsibility for any omissions or errors that may appear nor assumes liability for any damages or losses that result from the use of the products in accordance with the information contained in the manual or software.

Contents

1. General Description	1
2. Installation Procedures	2
2.1. Installing the Sensor	2
2.2. Installing the Cables & Liquid Filled Tubes	3
2.3. Installing the Reservoir	3
2.4. Taking Initial Readings	3
3. Flushing Procedures	4
4. Purging the Vent lines	5
5. In-Situ Calibration	5
6. In-Situ Zero Check	6
7. Special Tools & Apparatus Required for Test Procedures	7
8. Maintenance	7
9. Trouble Shooting	7
9.1. Unstable Readings	7
9.2. Readings of 9999	8
9.3. Sudden or Large Changes in Readings	8
10. Specifications	8
11. Taking Readings	8
12. Data Reduction	9
12.1 Calculation of Sensor Elevation	9
12.2 Correction for Settlement or Heave of the Reservoir Terminal	10
12.3 Corrections for Temperature	10
Appendix A. Resistance to Temperature Chart	12

1. General Description

The 4650 Settlement System is designed to measure the differential settlement between two points. A reservoir is located at a stable reference point and is connected to a sensor located at the settlement point by two liquid-filled tubes. The sensor senses the pressure of liquid within the tube and this provides a measure of the height of the liquid column and hence a measure of the elevation difference between the reservoir and the sensor.

Figure 1 shows a typical installation used to measure the settlement inside an embankment. The sensor is read by means of an electrical cable extending to the readout location. Readout may be by GK-401, GK-403, GK-404 or the Micro-10 Datalogger. The sensor contains a thermistor for measurement of temperature and also has gas discharge tubes for protection against lightning damage. The cable also contains a vent tube that connects the air inside the sensor to the space above the reservoir. This ensures that the sensor readings are unaffected by any changes in barometric pressure. A desiccant chamber located at the reservoir end of the vent line prevents moisture from migrating into the line.

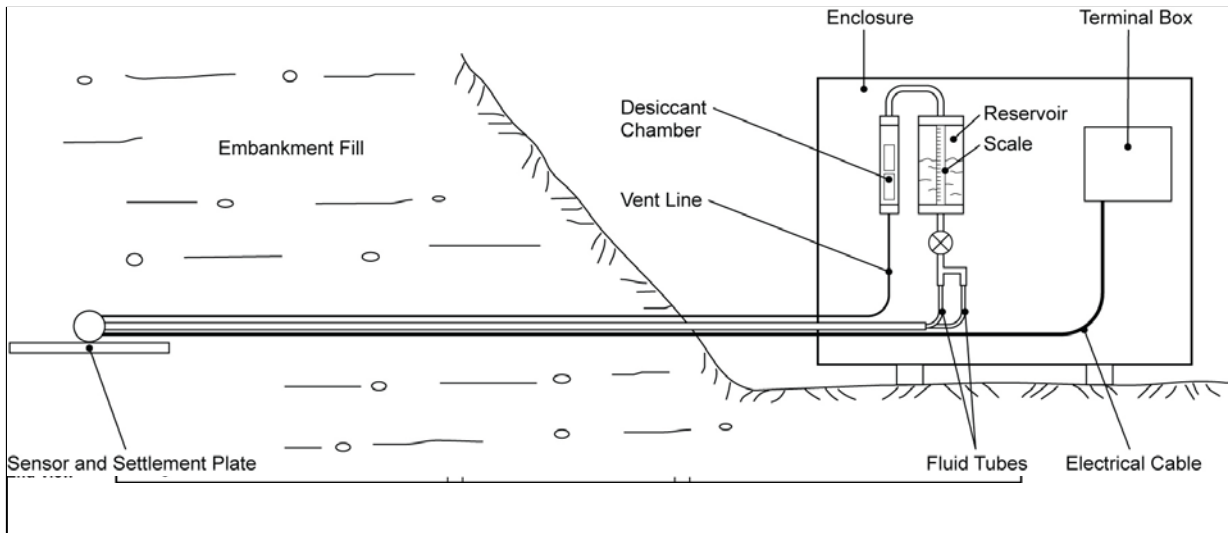

Figure 1. Typical installation of Vibrating Wire Settlement System.

Figure 2 shows details of the sensor.

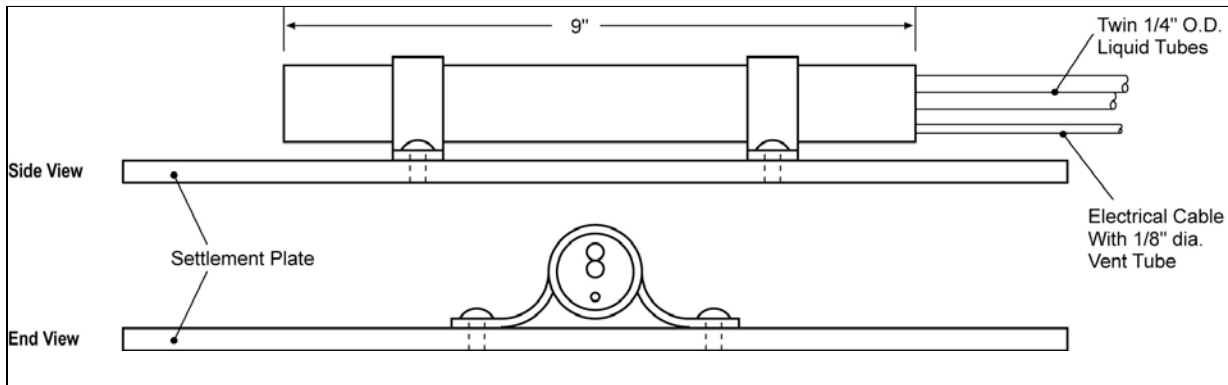

Figure 2. Sensor details.

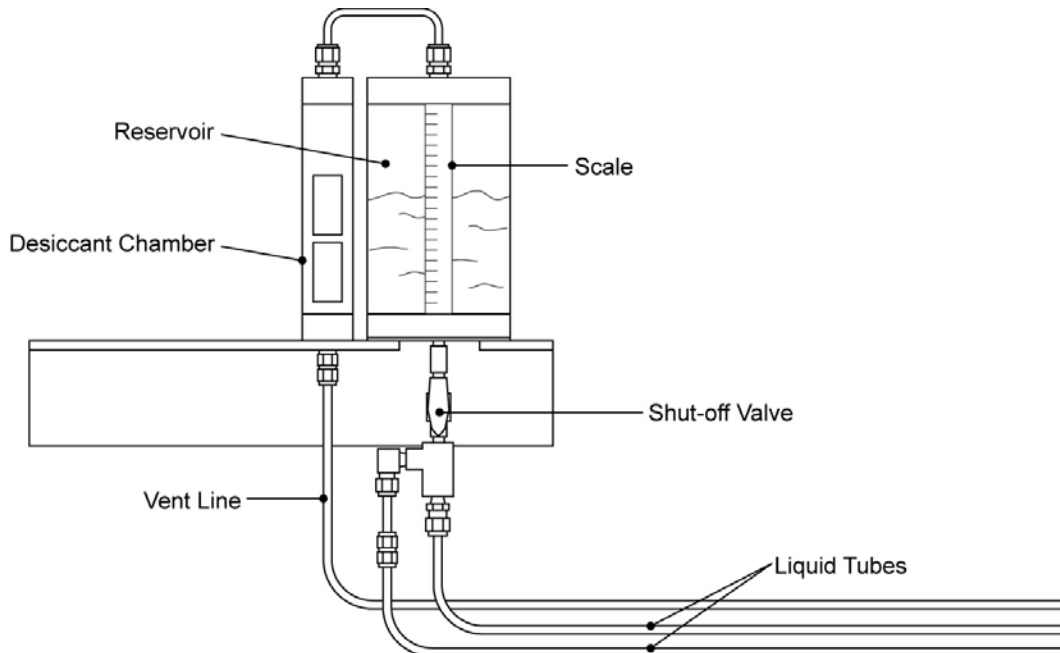

Figure 3. Reservoir Details.

than one sensor can be connected to a single reservoir. The use of two liquid-filled tubes permits the tubing to be flushed periodically to remove any accumulation of air bubbles. The liquid used is typically a de-aired antifreeze mixture, which resists the growth of algae and is not susceptible to freezing.

2. Installation Procedures

Most installations are in fills and embankments where the sensor and cables are buried. Elsewhere the cables and sensors may be attached directly to structures undergoing settlement or heave. The reservoir location must always be at a higher elevation than the sensor and higher than any part of the liquid-filled connecting tube.

Pre-filled systems are usually delivered with de-aired antifreeze solution already in the liquid lines; an extra length of small diameter tubing is connected to the outer ends of the liquid lines to allow the system to breathe during transportation while simultaneously protecting the sensor from being over-ranged by temperature or pressure fluctuations and preventing the entry of air-bubbles into the main liquid lines.

Alternatively, systems may be provided with the tubing empty for filling in the field.

2.1 Installing the Sensor

The sensor is usually attached to a settlement plate using the bracket(s) provided.

The settlement plate might be attached directly to a structure, using bolts; in the case of installation in fills a smooth, flat-bottomed excavation should be made about 300 to 600mm deep. The sensor plate is placed on this flat surface and covered with fine material, similar to the fill, with all particles removed over 10mm size. This material should be tamped down around the cell until the excavation is filled back to the original ground surface.

The elevation of the settlement plate should be measured at the time of the installation using conventional level survey techniques. Check also that the sensor is still functioning after tamping.

2.2 Installing the Cables and Liquid-Filled Tubes

Cables and tubing need to be placed in a trench approximately 300 to 600 mm deep. The trench should not undulate and individual cables and tubes should be laid side by side without touching or crossing each other. In no place should the tubing be higher than the reservoir location. Before back-filling the trench examine the tubing for signs of air-bubbles: If any are noted the tubing will need to be flushed before initial readings are taken.

Compact the material in the trench around the cables. Do not allow large angular pieces of rock to rest directly on the cable. To prevent migration of water along the trench, bentonite plugs can be constructed at intervals.

Trenches in earth dam embankments should never penetrate entirely through the clay core. Compaction of the fill above the cables can proceed in a normal manner when the cover exceeds 600mm depth. Where cables are not buried they should be adequately supported along their length to prevent undulations. They should also be protected from direct sunlight and insulated from rapid temperature fluctuations by encasing them in styrofoam or urethane foam, etc.

2.3 Installing the Reservoir

The reservoir should be installed on stable ground or at a location that can be level surveyed. The terminal housing should be affixed to stakes grouted firmly into the ground or preferably into a concrete pad poured at a location. The elevation of the reservoir pad should be surveyed and recorded at the time of installation. Remove the top fitting from the sight tube and fill the reservoir with de-aired antifreeze solution until it is half full as shown by the sight tube. The reservoir should never be located where it is exposed to direct sunlight.

When connecting the tubes from the sensor to the reservoir do not allow air to be trapped inside the tubing. Make sure that the vent line to the sensor is not blocked. This can be checked using an aspirator bulb to draw a vacuum on the vent line while observing the sensor reading on the GK-401, GK-403 or GK-404 readout box. Attach the vent line to the vent line manifold and add fresh desiccant to the desiccant chamber (or the vent line manifold)

A few drops of light oil added through the top of the reservoir will prevent evaporation from the liquid surface. Make sure that the connecting tubing between the vent line manifold (or desiccant chamber) and the reservoir is not blocked.

Connect the sensor cable to the terminal panel, if one exists: Black and Red wires are connected to the gage position; Green and White wires are connected to the thermistor (temperature) position. Manual switch panels can be used in conjunction with GK-401 or GK-403 readout boxes. Terminal strips are used in conjunction with dataloggers.

2.4 Taking Initial Readings

Initial readings must be taken with great care; they are the base line readings to which all subsequent readings are compared. It is important that the liquid-filled tubes be at a constant temperature. If the tubes are not completely buried the readings should be taken at a time when the temperature is relatively constant; certainly the readings should never be taken when the tubes are exposed to direct sunlight. Also, there should be no air bubbles in the

liquid tubes. If air bubbles are detected the tubes should be flushed before the initial readings are taken. If there is any doubt, take readings, flush the tubing and again take readings. Repeat if necessary until the readings are stable.

Take careful measurement of the elevation of the liquid level inside the reservoir sight tube. Make a mark on the tube opposite the liquid level. This will serve as a quick visual check on any fluctuations and enable a quick means of measuring the magnitude of the change for correction of subsequent calculations of settlement (see section 12) Reservoir level fluctuations may be due to temperature or pressure fluctuations or due to leakage. Record the ambient temperature.

3. Flushing Procedures

Periodic flushing of the liquid-filled tubes may be required to remove air bubbles. Tubes should always be filled with de-aired liquid. The best way to de-air a liquid is to use a Nold DeAerator (ask Geokon for more details). De-aired liquid is also available from Geokon in 2 gallon or 5-gallon pressure tanks specially designed to prevent air from reaching the fluid. The liquid should also resist the growth of algae and should not be liable to freeze in cold climates. The growth of algae can be prevented by dissolving a crystal of copper sulfate in the liquid or by using commercial grade ethylene glycol solutions, which also prevent freezing. The use of distilled water, rather than tap water, is recommended. Figure 4 shows the apparatus recommended for flushing the tubes.

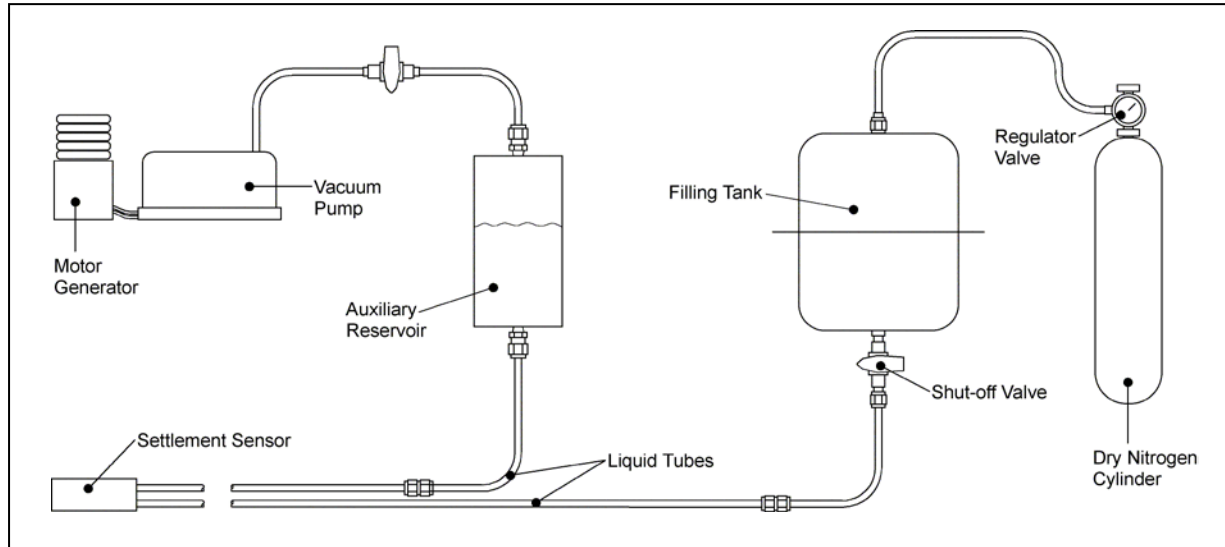

Figure 4. Flushing Apparatus

The shut off valve at the base of the reservoir is closed; one of the tubes is disconnected and then reconnected to the base of the filling tank filled with de-aired liquid. The second tube is disconnected and attached to the base of an auxiliary reservoir. To speed up the flushing process (for tubes longer than 200m) it is recommended that a vacuum pump be attached to the top of the auxiliary reservoir. A nitrogen cylinder with regulator is connected to the top of the filling tank. Start the vacuum pump running then open the valve at the bottom of the pressure tank. Adjust the nitrogen pressure until the settlement sensor reads at its maximum range value on either a GK-401 or GK-403 Readout Box. Be careful not to over range the sensor by more than 20%. Do not allow the nitrogen

pressure to exceed the pressure rating marked on the outside of the filling tank (usually 100 psi (700kPa). **Failure to observe this precaution could result in injury.** As flushing proceeds, the auxiliary reservoir may need to be emptied periodically. Store the flushed liquid in a container for later disposal. Do not allow any liquid to enter the vacuum pump as this could ruin it. Continue flushing until all the old liquid has been removed. Dye, added to the new flushing fluid, can be used to indicate when the flushing is complete. A 300-meter length of tubing requires 2.5 liters (0.67 gallons) of liquid. When flushing is complete reconnect the fluid lines to the base of the reservoir being careful not to introduce air-bubbles during the process.

4. Purging the Vent Lines _____

The vent line must remain open at all times connecting the inside of the sensor to the space above the reservoir. Any blockage of the vent line due to pinching, dirt, or moisture will cause false readings that fluctuate and/or are sensitive to temperatures.

Blockages due to pinched tubes can be confirmed by applying a vacuum to the vent line and observing the reading on the sensor. If the sensor does not respond the tube is blocked by dirt or pinched, and this might be correctable if the blockage is accessible. Blockages due to moisture and condensation can be purged using a vacuum pump to evacuate the vent line. As the vacuum is applied watch for signs of water in the vent line. When the vacuum has stabilized stop the pump, disconnect the vent line and quickly re-attach either a desiccant chamber containing fresh desiccant, or a cylinder of dry nitrogen. This ensures that the gas drawn back into the vent line is dry. Check that the vent line connection is open between the desiccant chamber (or vent line manifold) and the top of the reservoir.

5. In-Situ Calibration _____

A valuable feature of the Model 4650 settlement system is the ability to perform in-situ calibrations. This is done by connecting an auxiliary reservoir to one of the fluid lines as shown in figure 5.

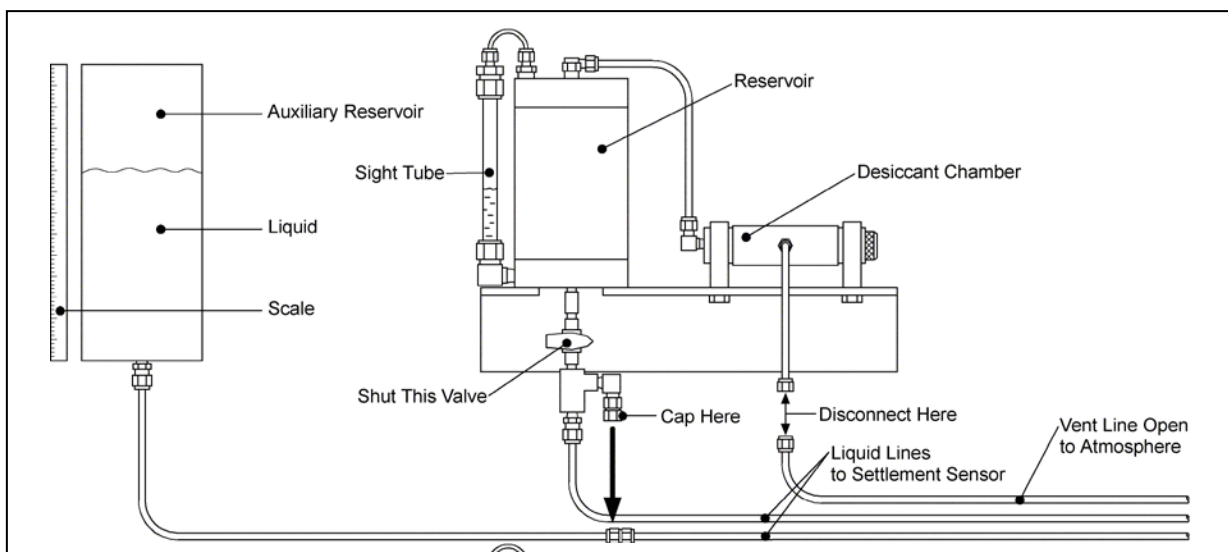

Figure 5. In-Situ Calibration Apparatus.

First close off the valve at the bottom of the reservoir, half-fill the auxiliary reservoir with the same liquid used in the reservoir and connect it via a short length of tubing to one of the fluid lines, being careful not to introduce air into the lines. Cap off the open fitting on the reservoir connection and disconnect the vent line from the vent manifold. Raise and lower the auxiliary reservoir by measured amounts using a scale to measure the elevation of the water level. Read the sensor using a GK-401, GK-403 or GK-404 readout box. Record the readings after allowing sufficient time for the readings to stabilize (usually requires around 1 to 5 minutes although it will be noted that the sensor responds instantaneously to change of water elevation even where the liquid tubes are very long.) Record the sensor readings at five or more different elevations, then, from the data calculate the calibration factor and compare it with the factory-generated value on the calibration sheet. Remove the auxiliary reservoir and reconnect the fluid line to the base of the reservoir and the vent line to the desiccant chamber or vent line manifold. Re-open the valve at the base of the reservoir.

6. In-Situ Zero Check _____

This procedure is not recommended as a regular procedure but only one to be undertaken if there is some serious doubt as to the zero stability of the sensor or to confirm a sudden or critical change in the amount of settlement which is causing concern.

Disconnect the vent line from the desiccant chamber Close the valve at the bottom of the reservoir. Disconnect the liquid lines from the bottom of the reservoir connect one of them to a nitrogen cylinder. Turn on the nitrogen and adjust the pressure so that the sensor reading is at its maximum value. (Do not exceed 20% above this maximum range.) The other tube can be left open (with long lengths of tubing (> 200m) the process can be speed up by attaching a vacuum pump to the end of the other fluid line.) When all the liquid has been purged from the lines allow the nitrogen to flow for another 30 minutes. This will tend to dry out the inside of the tubing. Turn off the nitrogen and disconnect the ends of the tubing so that they are both open to atmosphere along with the open vent line. Wait until the sensor reading stabilizes and then record this zero reading. Compare this reading with the factory zero reading shown on the calibration chart.

Refill the liquid lines following the flushing procedures described in section 3 with the following difference: If a vacuum pump is used allow the vacuum pump to run for 30 minutes or until the sensor reading has stabilized before opening the valve at the bottom of the filling tank to allow liquid to enter the lines. This will greatly reduce the chances of air being trapped inside the tubing and sensor cavities.

7. Special Tools & Apparatus Required for Test Procedures

- GK-401 or GK-403 Readout Box
- Assorted wrenches
- Nitrogen supply cylinder with regulator valve
- Pressure tanks filled with de-aired liquid (45% anti-freeze solution made with distilled water and containing dye)
- Vacuum pump and rubber connecting hoses with pinch clamps
- Motor generator (Gasoline powered)
- Auxiliary reservoir
- Miscellaneous connecting tubes & fitting

8. Maintenance

Every 3 months

- Conduct a visual examination of the reservoir terminal housing. Check for leaks by observing the water level in the reservoir sight tube. Add additional fluid as necessary by removing the top connector of the Tygon sight tube. Alternatively, if the water level in the reservoir begins to rise this may be due to squeezing of the tubing by ground pressures. It is important not to let the fluid overflow from the reservoir into the vent line; this could adversely affect the readings, so drain off any excess fluid before it reaches the top of the reservoir. If regular maintenance is not possible then it is advisable to disconnect the tubing connecting the top of the reservoir to the desiccant chamber and leave them both open to the atmosphere.
- Replace the desiccant capsules in the vent line manifold or desiccant chamber. Desiccant capsules are dark blue when active and pink when inactive.

Every 12 months

- Flush the liquid tubes with fresh de-aired liquid.
- Check the in-situ calibration as described in section 5.

9. Trouble Shooting

Faulty readings may show up as unstable, fluctuating readings, sudden large changes of readings or readings of 9999 on dataloggers, unrelated to physical phenomena. The first task should be to see if the fault lies with the readout device. If a datalogger is in use, try reading the sensors with a portable GK-401 or GK-403 Readout box.

9.1 Unstable Readings

Unstable readings with dataloggers may be caused by electrical noise from nearby power lines or electrical equipment. Remove such equipment, if possible, or read the sensors when the power is switched off.

Fluctuating readings may also be the result of air-bubbles in the liquid lines or of plugged vent lines. Follow the procedures outlined in Section 3 & 4.

9.2 Reading of 9999

These will show up on dataloggers if the reading is over-range. This can happen if the electrical leads are shorted or open. Check the resistance between the black and red conductors. The resistance should be 180 ohms \pm 10 ohms plus 5 ohms for every 100 meters of lead wire. If the resistance is substantially different from these values check for loose connections in the terminal box and for visible signs of cable damage.

9.3 Sudden or Large Changes in Readings

May be caused by leakage of liquid from the liquid lines. Check the reservoir sight tube. If leakage is detected and there are more than one sensor connected to the reservoir turn off each sensor valve at the base of the reservoir one by one till the leaking sensor is found. If preferred this sensor can be left isolated from the system so as not to disrupt the others.

10. Specifications _____

Refer to the product literature sheets for specifications of the vibrating wire sensor transducer.

- Electrical cable – Model 02-335VT8, 2 shielded pairs 22 Ga. W/ ground wire and integral 1/8” diameter polyethylene vent tube. 0.375 inch diameter polyurethane jacket. Resistance 16 ohms/1000 ft. (5.25 ohm/100m)
- Liquid tubes- Twin type 11 nylon tubes ¼” O.D. covered with 1mm polyethylene jacket.
- Liquid – A de-aired 55/45 solution of distilled water mixed with commercial grade ethylene glycol. Specific gravity 1.07. Freezing point -30°C (-22°F).
- Desiccant Capsules- Geokon Model 4500-8

11. Taking Readings _____

Initial readings are taken as described in Section 2.4. Follow the instructions of either the Datalogger or portable readout box in use. The sensor is connected to the black and red leads the thermistor to the green and white leads. (Read the sensors on channel B)

When taking sensor readings record also the height of the fill above the sensor, the temperature and any other physical phenomena or construction activity that might affect the readings.

Temperature at the sensor location will be read automatically by a datalogger and by a GK-403 or GK 404 readout box. If a GK-401 is in use the sensor thermistor can be read using an ohmmeter to measure the resistance.

Appendix 1 gives a reference table for converting resistance to temperature. Be sure to allow for the resistance of the sensor cable (5.25 ohms per 100m).

12. Data Reduction

12.1 Calculation of Sensor Elevation

Readings can be used to calculate the elevation of the sensor and to plot them on a graph versus time. The graph should also show the elevation of the fill above the sensor at the time of each reading. A plot of temperature can also be included. For the standard 4650 settlement system using type 4500 SV or 4500 ALV transducers the readings will get smaller as the sensors settle relative to the reservoir.

For these sensors the elevation, E, of the sensor is given by:

$$E = E_0 - (R_0 - R_1) G - \Delta E_{RES}. \text{ Meters}$$

Where E_0 is the sensor elevation at installation.

ΔE_{RES} is any change of the fluid level inside the reservoir sight glass. If the fluid level falls, ΔE_{RES} is negative. If the fluid level rises, ΔE_{RES} is positive.

R_0 is the initial sensor reading

R_1 is the subsequent sensor reading

G is the calibration factor supplied with the sensor

A typical calibration sheet as, supplied by the factory, is shown in figure 6 (on page 11).

Example:

$$E_0 = 541.623 \text{ meters}$$

$$R_0 = 9030$$

$$R_1 = 8800$$

$$G = 0.00140 \text{ meters/digit}$$

$\Delta E_{RES} = -10\text{mm}$ (i.e. the level of water in the reservoir sight tube is 10mm lower than the level measure at the time of the initial reading).

So the new sensor elevation is

$$E = 541.623 - ((9030 - 8800) 0.00140 - (-0.010))$$

$$E = 541.291 \text{ meters}$$

Or, in other words, there has been a settlement of 0.332meters.

12.2 Calculation of Settlement

The amount of settlement, S , of the sensor is given by the equation

$$S = (R_0 - R_1) G - \Delta E_{RES}. \text{ Meters}$$

So in the last example, $S = (9030 - 8800) 0.00140 - (-0.010) = 0.332$ meters

12.3 Correction for Settlement or Heave of the Reservoir Terminal

Periodic level surveys should be made of the elevation of the concrete pad on which the reservoir terminal is located. Any settlement should be subtracted from the calculated sensor elevations.

12.4 Corrections for Temperature

Temperature effects on liquid volume (liquid density) and on the expansion and contraction of the liquid confines can be quite complex and in some ways self canceling. Liquid lines in fills are generally well insulated so that temperature effects tend to be insignificant. Systems exposed to the atmosphere and to sunlight may suffer from rapidly changing temperatures at different parts of the system causing significant fluctuation of the readings. In such cases precautions may be necessary to obtain readings at times of maximum temperature stability.

Temperature effects on the sensor can be corrected for but are usually quite insignificant especially if the sensor is buried.

The temperature correction to the elevation, E_T , is given by:

$$E = E_0 - ((R_0 - R_1) G - \Delta E_{RES.}) - (T_1 - T_0) K$$

The temperature correction to the settlement, E_T , is given by:

$$S = (R_0 - R_1) G - \Delta E_{RES} + (T_1 - T_0) K$$

Where T_0 is the initial temperature, T_1 is the current temperature and K is the temperature correction factor included on the calibration sheet.

APPENDIX A – STANDARD TEMPERATURE THERMISTOR TEMPERATURE DERIVATION

Thermistor Type: YSI 44005, Dale #1C3001-B3, Alpha #13A3001-B3

Resistance to Temperature Equation B1:

$$T = \frac{1}{A + B(\ln R) + C(\ln R)^3} - 273.2$$

Where; T = Temperature in °C.

LnR = Natural Log of Thermistor Resistance

A = 1.4051×10^{-3} (coefficients calculated over the -50 to +150° C. span)

B = 2.369×10^{-4}

C = 1.019×10^{-7}

Ohms	Temp	Ohms	Temp	Ohms	Temp	Ohms	Temp	Ohms	Temp
201.1K	-50	16.60K	-10	2417	+30	525.4	+70	153.2	+110
187.3K	-49	15.72K	-9	2317	31	507.8	71	149.0	111
174.5K	-48	14.90K	-8	2221	32	490.9	72	145.0	112
162.7K	-47	14.12K	-7	2130	33	474.7	73	141.1	113
151.7K	-46	13.39K	-6	2042	34	459.0	74	137.2	114
141.6K	-45	12.70K	-5	1959	35	444.0	75	133.6	115
132.2K	-44	12.05K	-4	1880	36	429.5	76	130.0	116
123.5K	-43	11.44K	-3	1805	37	415.6	77	126.5	117
115.4K	-42	10.86K	-2	1733	38	402.2	78	123.2	118
107.9K	-41	10.31K	-1	1664	39	389.3	79	119.9	119
101.0K	-40	9796	0	1598	40	376.9	80	116.8	120
94.48K	-39	9310	+1	1535	41	364.9	81	113.8	121
88.46K	-38	8851	2	1475	42	353.4	82	110.8	122
82.87K	-37	8417	3	1418	43	342.2	83	107.9	123
77.66K	-36	8006	4	1363	44	331.5	84	105.2	124
72.81K	-35	7618	5	1310	45	321.2	85	102.5	125
68.30K	-34	7252	6	1260	46	311.3	86	99.9	126
64.09K	-33	6905	7	1212	47	301.7	87	97.3	127
60.17K	-32	6576	8	1167	48	292.4	88	94.9	128
56.51K	-31	6265	9	1123	49	283.5	89	92.5	129
53.10K	-30	5971	10	1081	50	274.9	90	90.2	130
49.91K	-29	5692	11	1040	51	266.6	91	87.9	131
46.94K	-28	5427	12	1002	52	258.6	92	85.7	132
44.16K	-27	5177	13	965.0	53	250.9	93	83.6	133
41.56K	-26	4939	14	929.6	54	243.4	94	81.6	134
39.13K	-25	4714	15	895.8	55	236.2	95	79.6	135
36.86K	-24	4500	16	863.3	56	229.3	96	77.6	136
34.73K	-23	4297	17	832.2	57	222.6	97	75.8	137
32.74K	-22	4105	18	802.3	58	216.1	98	73.9	138
30.87K	-21	3922	19	773.7	59	209.8	99	72.2	139
29.13K	-20	3748	20	746.3	60	203.8	100	70.4	140
27.49K	-19	3583	21	719.9	61	197.9	101	68.8	141
25.95K	-18	3426	22	694.7	62	192.2	102	67.1	142
24.51K	-17	3277	23	670.4	63	186.8	103	65.5	143
23.16K	-16	3135	24	647.1	64	181.5	104	64.0	144
21.89K	-15	3000	25	624.7	65	176.4	105	62.5	145
20.70K	-14	2872	26	603.3	66	171.4	106	61.1	146
19.58K	-13	2750	27	582.6	67	166.7	107	59.6	147
18.52K	-12	2633	28	562.8	68	162.0	108	58.3	148
17.53K	-11	2523	29	543.7	69	157.6	109	56.8	149
								55.6	150