

# Model 801 Tuff Tilt



140 Chestnut Street  
San Francisco, CA 94111  
Phone: 415-364-3200  
Fax: 415-861-1448  
[www.geomechanics.com](http://www.geomechanics.com)  
sales@geomechanics.com

**WARNING!**

*NEVER USE AN OHMMETER TO MEASURE THE TILT SENSORS INSIDE THE TILTMETER. APPLYING DC CURRENT THROUGH THE SENSORS WILL CAUSE PERMANENT DAMAGE THAT IS NOT COVERED BY THE WARRANTY.*

Copyright ©2009 by Applied Geomechanics Inc. All rights reserved.  
Manual No. B-97-1010, Rev. E. Printed in USA.

## TABLE OF CONTENTS

<b>1. INTRODUCTION.....</b>	<b>1</b>
<b>2. TECHNICAL FEATURES.....</b>	<b>1</b>
<b>3. SPECIFICATIONS.....</b>	<b>2</b>
<b>4. USING THE MODEL 870 READOUT MODULE.....</b>	<b>3</b>
<b>5. TILTMETER OPERATION.....</b>	<b>3</b>
5.1 INITIAL CHECK-OUT PROCEDURES.....	3
5.2 TILTMETER INSTALLATION.....	4
5.3 RECORDING TILTMETER DATA WITH EXTERNAL RECORDERS.....	4
<b>6. CONVERTING OUTPUT READINGS TO TILT ANGLES AND TEMPERATURES.....</b>	<b>5</b>
<b>7. GROUNDING AND TRANSIENT PROTECTION.....</b>	<b>5</b>
<b>8. MAINTENANCE AND TROUBLESHOOTING.....</b>	<b>6</b>
8.1 ROUTINE MAINTENANCE.....	6
8.2 DETERMINING THE CAUSE OF MALFUNCTIONS.....	6
<b>9. MODEL 870 BATTERY REPLACEMENT.....</b>	<b>7</b>
<b>10. WARRANTY AND ASSISTANCE.....</b>	<b>7</b>

### List of Figures

<b>1</b>	<b>Model 801 Tiltmeter – Longitudinal Tilt Style.....</b>	<b>8</b>
<b>2</b>	<b>Model 801 Tiltmeter – Transverse Tilt Style.....</b>	<b>8</b>
<b>3</b>	<b>Model 870 Readout Module.....</b>	<b>9</b>
<b>4</b>	<b>Mounting Screw Insertion.....</b>	<b>9</b>
<b>5</b>	<b>Mounting Hole Pattern.....</b>	<b>10</b>
<b>6</b>	<b>Using P/N 81439 Mounting Bracket.....</b>	<b>10</b>
<b>7</b>	<b>Double Nutting Mounting Screws for Fine Level Adjustment.....</b>	<b>11</b>
<b>8</b>	<b>Circuit Board Inside Model 801 Enclosure.....</b>	<b>11</b>

### Appendices

<b>A</b>	<b>Custom Specifications for Your Equipment; Connectors and Wiring.....</b>	<b>12</b>
----------	---	-----------

## 1. Introduction

The Model 801 Tuff Tilt Uniaxial Tiltmeter is an economical uniaxial tiltmeter for a wide variety of monitoring and measurement applications. It incorporates a high-precision electrolytic tilt transducer as the internal sensing element, offering unrivaled resolution and long-term stability. Measured angular movement is referenced to the unchanging vertical gravity vector, eliminating the time and expense of locating an external datum. Your Model 801 is ideal for a wide variety of engineering projects including: structural behavior testing, monitoring of foundation conditions, surveillance of natural and manmade structures, and machine positioning and control.

Model 801 tiltmeters are available in high-gain ( $\pm 0.5^\circ$  range), standard ( $\pm 3^\circ$  range) and wide-angle ( $\pm 50^\circ$  range) versions. Each of these versions is produced in both longitudinal and transverse tilt styles (Figures 1 and 2). Range and tilt style are specified when ordering.

The Model 870 Readout Module is used for rapid leveling and on-the-spot reading of Model 801 tiltmeters (Figure 3). This low-cost module plugs into any digital multimeter to display the tiltmeter output. Model 870 reads tilt and temperature, and checks its own internal battery.

## 2. Technical Features

Your Model 801 Uniaxial Tiltmeter is rugged and field-proven - intended for use in harsh outdoor environments, in the laboratory or on the factory floor. The tilt sensor and electronic signal conditioning circuitry are housed in a NEMA 4X rated, die-cast aluminum enclosure. Holes in the enclosure, accessed by removing the cover (Figure 4) are provided for mounting the tiltmeter. High-reliability components and surge protection enhance performance under electrically noisy or transient-prone conditions. A low-pass filter removes vibration effects for static measurements. A built-in temperature sensor provides the data necessary for analysis of thermal deformation and stresses. The high-level voltage outputs of the tiltmeter are easily interfaced to any conventional recording system.

Your tiltmeter senses angular movement (rotation) with respect to the vertical gravity vector. The sensing element is an electrolytic tilt transducer, similar to a spirit level. As the transducer tilts, internal electrodes are covered or uncovered by a conductive fluid. This process produces changes in electrical resistance when an AC excitation is passed through the transducer. These changes are measured using a voltage divider network. The resulting signal is then amplified, actively rectified and filtered to form a high-level DC signal that is proportional to the measured angular rotation, or tilt

Other important features include the following:

- All electronics reside on a single internal printed-circuit board.
- All circuit board external connections are gold-plated for long life and noise-free operation.

- All resistors are premium quality, 1% tolerance, metal-film type.
- All tiltmeters are hand-assembled, calibrated, and tested at our plant under stringent quality control standards.
- AGI maintains complete specifications and test records of every tiltmeter built.

### 3. Specifications

	Model 801-H High-Gain Version	Model 801-S Standard Version	Model 801-W Wide-Angle Version
ANGULAR RANGE	±0.5 degrees	±3 degrees	±50 degrees*
SCALE FACTOR†	0.1°/ volt (single-ended)	0.6°/ volt (single-ended)	10°/ volt (single-ended)
RESOLUTION	<0.0001 degree (<1.75 μradians)	0.0006 degree (10.5 μradians)	0.01 degree
REPEATABILITY	<0.0002 degree	0.001 degree	0.02 degree
LINEARITY	1% of full span typical	<2% of full span typical	0.5% of full span typical
TEMPERATURE COEF.	Scale factor: $K_S < 0.02\%/^{\circ}\text{C}$ typ. Zero shift: $K_Z = \pm 0.0002$ degree/ $^{\circ}\text{C}$	$K_S < 0.02\%/^{\circ}\text{C}$ typ. $K_Z = \pm 0.0002$ degree/ $^{\circ}\text{C}$ typ.	$K_S < 0.02\%/^{\circ}\text{C}$ typ. $K_Z = \pm 0.002$ degree/ $^{\circ}\text{C}$ typ.
TIME CONSTANT, $T$	1.75 seconds (2-pole Butterworth low-pass filter), faster response available		0.15 second
TILT OUTPUT	± 5 VDC single-ended, ±10 VDC differential (both provided)		
TEMPERATURE OUTPUT	0.1°C/mV (single-ended), -40° to +100°C, ±0.75°C accuracy, 0°C = 0 mV		
OUTPUT IMPEDANCE	270 Ohms, short circuit and surge protected		
POWER REQ'TS.	+8 to +18 VDC @ 8 mA, 250 mV peak-to-peak ripple max., reverse polarity protected		
ENVIRONMENTAL	-25° to +70° C operating, -30° to +100° C storage; NEMA 4X (IP-65) (wet conditions, nonsubmersible)		
ENCLOSURE & MOUNTING	Painted, die-cast aluminum box, 120 x 80 x 60 mm. Four 4.4 mm dia. mounting holes on 107 x 67 mm (4.21 x 2.64 in) centers		
CABLE	3m (10 ft), 6-conductor + one overall shield, PVC jacket, tinned ends		
WEIGHT	0.6 kg (1.5 lb)		

\* greater range available

† Divide by 2 for differential scale factor.

## 4. Using the Model 870 Readout Module

The Model 870 Readout Module is used for installation, check-out and releveling of Model 801 tiltmeters, as well as for collecting tilt data at periodic intervals. The Model 870 Readout Module is designed for use with any hand-held voltmeter or multimeter containing banana plug sockets with standard 0.75-inch center-to-center separation (Figure 3). Most hand-held multimeters on the market today fit this description. The Model 870 Readout Module powers the tiltmeter from one 9-volt battery housed in its ABS plastic case.

To use the Readout Module, first plug it into your tiltmeter via the 6-pin connector or terminal strip at the end of its cable (see Appendix A for wire color coding). Then plug the Readout Module into your multimeter via the banana jacks. Set the multimeter to its “DC Volts” setting and turn it on. Turn the TILT-OFF-TEMPERATURE switch on the Readout Module to the TILT or TEMPERATURE position (this switches power to the tiltmeter). Now, depress the BATTERY CHECK button on the Readout Module to observe the battery voltage on the display of the multimeter. If the level is below 8 volts, replace the internal battery with a new, fresh battery. To replace the battery, follow the instructions in Section 9 “Model 870 Battery Replacement.”

After completing the above battery check, you are ready to read your tiltmeter. Turn the toggle switch to TILT and read the voltage output on the multimeter display. The multimeter must be in the “DC Volts” setting. The displayed number (volts or millivolts) may be converted to the tiltmeter angle using the scale factor in Appendix A (see Section 6 “Converting Output Readings to Tilt Angles and Temperatures”).

To read the tiltmeter temperature, turn the toggle switch to TEMPERATURE. The displayed number is in volts and may be converted to temperature using the temperature sensor scale factor in Appendix A.

The Model 870 Readout Module is protected from light rain and splashes in the field by its case design. However, it is not waterproof and may leak if submerged or exposed to heavy rainfall. It should be protected from water if used in wet climates or conditions.

## 5. Tiltmeter Operation

### 5.1 Initial Check-Out Procedures

Before installing your tiltmeter, verify that it is functioning properly by following the steps below:

1. Connect the tiltmeter to the Model 870 Readout Module and connect the Readout Module to a voltmeter or multimeter, as described above.
2. Turn the Readout Module switch to TILT.

3. Refer to the (+) and (-) tilt directions in Figure 1 or 2 (also shown on a label on your tiltmeter). With the tiltmeter in your hands, rotate it to verify the sign (polarity) of the outputs. A rotation in the (+) direction should make the voltage output become more positive.
4. Check that the tiltmeter output moves through its full range of approximately +5 volts to -5 volts. The output that is displayed on the voltmeter is the single-ended output of the tiltmeter. Positive output may be greater than +5 volts.
5. Turn the Readout Module switch to TEMPERATURE. Verify that the temperature sensor output accurately approximates the temperature in your location. For example, a room temperature of 20°C (68°F) should give a voltage output of 200 mV (0.200 volts). The temperature sensor scale factor is 0.1°C/mV.

## 5.2 Tiltmeter Installation

Your Model 801 Tiltmeter is designed to be mounted directly on a solid horizontal surface using four No. 8-32 cap screws, which are supplied with each tiltmeter. The surface may be drilled and tapped to accept the screws, or through-holes may be drilled and the screws attached with nuts and washers on the underside of the surface. The mounting holes are accessed by first removing the tiltmeter cover (Figure 4). The mounting hole pattern is shown in Figure 5. For mounting on vertical surfaces the optional angle mounting bracket is used (part no. 1439, Figure 6).

It is also possible to use a double-nutted mounting arrangement to allow for leveling of the tiltmeter (Figure 7). This technique is typically used with the Model 801-H high-gain tiltmeter because of its narrow angular range. It is important to adjust the leveling nuts slowly in sequence while observing the readout to obtain level (reading of approximately zero volts).

Other methods have also been used successfully to install Model 801 tiltmeters. For example, in ground movement monitoring applications a shallow hole may be dug and then partially filled with dry sand. The tiltmeter can then be placed directly on the sand and leveled by hand. This method is often effective if the tiltmeter is unlikely to be disturbed during the monitoring period. If placed in a hole, care should be taken to prevent flooding of the tiltmeter during wet weather.

It is sometimes possible to clamp the tiltmeter to a metal plate or flange. “C” clamps may be used for this purpose.

## 5.3 Recording Tiltmeter Data with External Recorders

The analog output of your Model 801 tiltmeter is readily measured by a variety of external devices, including digital voltmeters, oscilloscopes, strip-chart recorders, data-loggers, and PC-based data acquisition systems. You will need to connect your tiltmeter cable to a suitable external power supply and to the inputs of your recording device. Refer

to the cable color coding table in Appendix A for the information you'll need to make these connections.

## 6. Converting Output Readings to Tilt Angles and Temperatures

The tiltmeter voltage outputs are quickly converted to tilt angles as follows: multiply the voltage reading by the scale factor supplied in Appendix A. For example, if the scale factor is 0.600 degrees/volt and the voltage reading is +2.000 volts, then the tilt angle is +1.200 degrees from sensor null.

Similarly, the voltage reading from the tiltmeter temperature sensor is converted to temperature by multiplying it a scale factor of 0.1°C/mV (100°C/volt), with 0 mV = 0°C.

## 7. Grounding and Transient Protection

Your tiltmeter has separate power ground and signal ground wires in the tiltmeter cable. Both are connected (common) inside the tiltmeter. Signal Ground is the reference state for single-ended tilt measurements and for readings of temperature. *We recommend that you do not connect the Power Ground and Signal Ground wires in your cable at your power supply or recorder.* Current to power the tiltmeter flows in the power ground wire and, because of wire resistance, the ground potential is different at opposite ends of this wire. By keeping signal ground separate from power ground, your tilt and temperature readings will not be affected by this potential difference.

If you ground the power ground wire to earth, do so at one end only. Earthing in more than one location can produce ground loops and create unstable readings.

Variable resistance type surge absorbers connect each wire in the tiltmeter cable to the metal enclosure that houses your tiltmeter. Connecting the enclosure to a grounding rod, or other form of earth ground, will reduce the likelihood of an electronic failure caused by high-voltage transients. Such transients can be caused by nearby lightning strikes or unstable power sources. Grounding the cable shield to earth at the power supply end can also help avoid transient-induced damage and can reduce noise in your measurements. Note that the cable shield is terminated at the tiltmeter enclosure and is not connected to the metal tiltmeter enclosure.

High-voltage transients are the most common cause of failure of field instruments in outdoor installations. In a typical occurrence, a high-voltage spike from a lightning strike or power surge travels along the cable until it encounters the instrument's electronic circuitry, where the delicate low-voltage components are overloaded and fail. The protections provided in your tiltmeter reduce the likelihood of failure. Commercially available surge suppression circuitry can provide additional protection for your field installations.

## 8. Maintenance and Troubleshooting

### 8.1 Routine Maintenance

The routine maintenance procedures given here will help ensure that your **Tuff Tilt** tiltmeter provides many years of trouble-free service.

Keep your tiltmeter clean and away from extremes of heat and cold. Dirt and extreme temperatures shorten the life of the seals and unnecessarily stress the electronic components. Keep the tiltmeter out of direct sun because solar radiation can create internal temperatures considerably greater than the ambient temperature.

The Model 801 is housed in a NEMA 4X rated enclosure. This means that it is protected against splashes, rainfall and hose-down conditions. However, neither it nor the Model 870 Readout Modules are fully waterproof and they should NEVER BE SUBMERGED in water or any other liquid. WATER DAMAGE TO INTERNAL COMPONENTS VOIDS THE WARRANTY!

**WARNING:** NEVER USE AN OHMMETER TO MEASURE THE TILT SENSORS INSIDE THE TILTMETER. APPLYING DC CURRENT THROUGH THE SENSORS WILL CAUSE PERMANENT DAMAGE THAT IS NOT COVERED BY THE WARRANTY. The tilt sensor connections to the circuit board are shown in Figure 8. NEVER use an ohmmeter at these locations.

### 8.2 Determining the Cause of Malfunctions

Apart from the procedures described below, Model 801 tiltmeters are not field serviceable. If you encounter problems not described here, please contact Applied Geomechanics Inc. at telephone (831) 462-2801, fax (831) 462-4418, or e-mail support at [service@geomechanics.com](mailto:service@geomechanics.com). A service engineer will assist you in determining the cause of any problem.

If there is no output when you have connected the tiltmeter to the Model 870 Readout Module or other recording system, first check that the Readout Module, multimeter or recording device has adequate power and is functioning properly. Then be sure that all connectors are securely attached. *Failure to obtain an output signal from the tiltmeter normally is the result of lack of power or a broken wire or connection.*

If the tiltmeter output is firmly “pegged” at either end of the output range, the tiltmeter is probably tilted off scale. Rotate the tiltmeter in the opposite tilt direction to check this possibility. The tiltmeter output should pass through zero volts as you move it through its null (level) position. Remember that the response is not instantaneous because of the time constant of the filter. However, no more than a few seconds should elapse before the tiltmeter responds as it moves through null.

If the tiltmeter output remains “pegged” at its positive or negative limit no matter how much you move it, the cause may be a broken connection or short circuit where the sensor lead wires connect to the printed circuit board. In this event, or if you have otherwise established that a problem is internal to the tiltmeter, contact the factory for assistance or to arrange for a repair.

## **9. Model 870 Battery Replacement**

If the voltage level of the Readout Module battery drops below 8 volts, it should be replaced. The battery is a standard 9-volt radio battery, available in most supermarkets and hardware stores. To replace the battery, follow the steps below:

1. Remove the four metal screws from the back panel.
2. Carefully separate the back panel from the front portion of the Readout Module. Do not twist or pull the internal wiring.
3. Replace the old battery with a fresh new battery.
4. Replace the back panel, taking care not to pinch any of the wires.
5. Replace the four metal screws that attach the back panel to the front portion of the Readout Module. Do not overtighten.

After you have replaced the battery, connect the Readout Module to a or multimeter and to your tiltmeter to verify that is it working properly. Using the procedures outlined in Sections 4 and 5, verify that the Readout Module reads tilt, temperature and battery voltage.

## **10. Warranty and Assistance**

Model 801 Tiltmeters and Model 870 Readout Module are warranted against defects in materials and workmanship for one year from the date of delivery. We will repair or replace (at our option) products that prove to be defective during the warranty period provided they are returned prepaid to Applied Geomechanics Inc. (AGI). No other warranty is expressed or implied. The warranty is void if the equipment is submerged in water or other liquid, if it is subjected to lightning strikes or other large potential gradients, or if it is otherwise used contrary to the directions herein. After expiration of the warranty, AGI will repair the equipment at its factory for parts and labor charges. Products returned after warranty expiration should be accompanied by a purchase order to cover repair costs. Applied Geomechanics Inc. is not liable for consequential damages.

**THE REMEDIES PROVIDED HEREIN ARE THE BUYER’S SOLE AND EXCLUSIVE REMEDIES. AGI SHALL NOT BE LIABLE FOR ANY DIRECT, INDIRECT, SPECIAL, INCIDENTAL OR CONSEQUENTIAL DAMAGES, WHETHER BASED ON CONTRACT, TORT OR ANY OTHER LEGAL THEORY.**

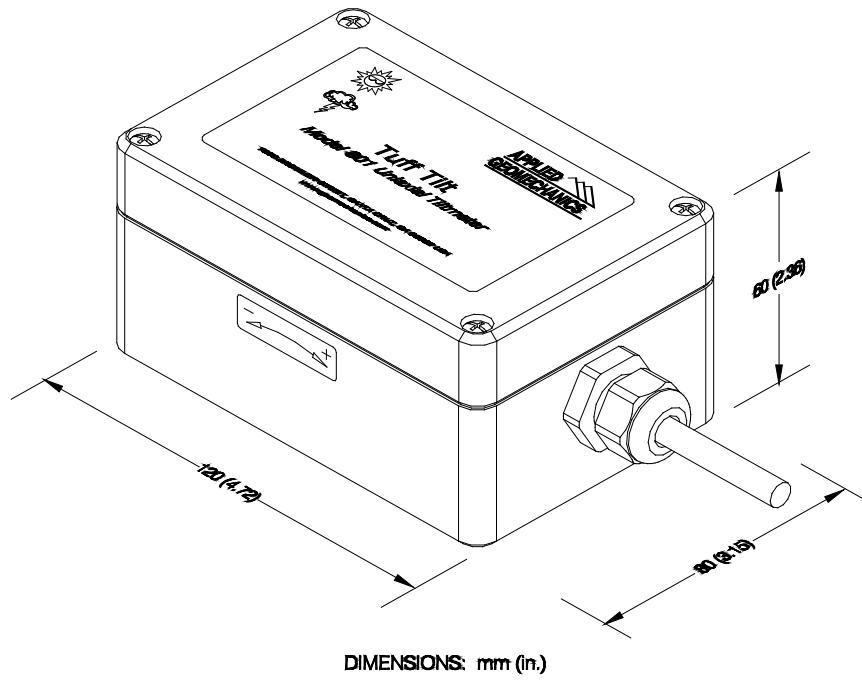

Figure 1. Model 801 Tiltmeter - Longitudinal Tilt Style

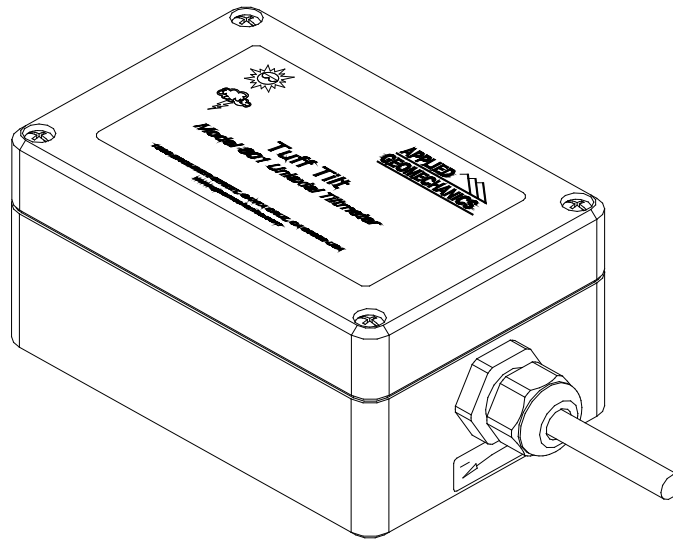

Figure 2. Model 801 Tiltmeter - Transverse Tilt Style

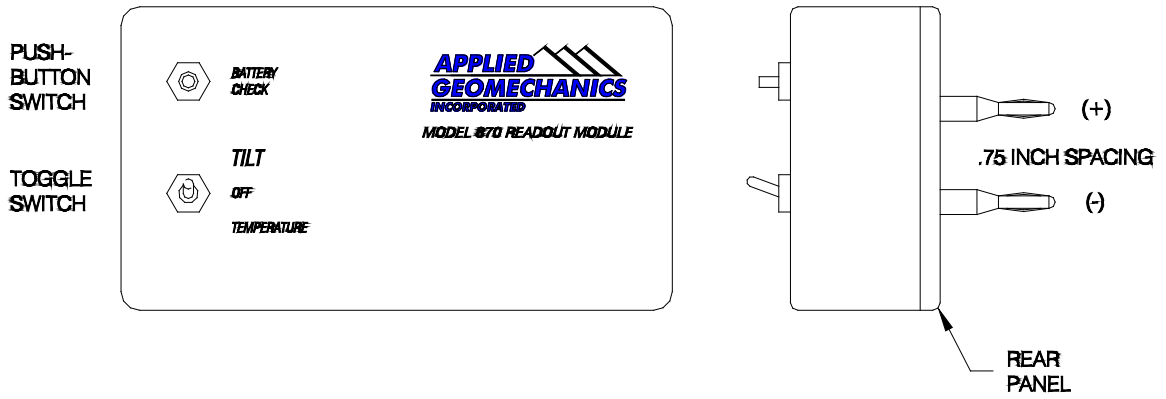

Figure 3. Model 870 Readout Module

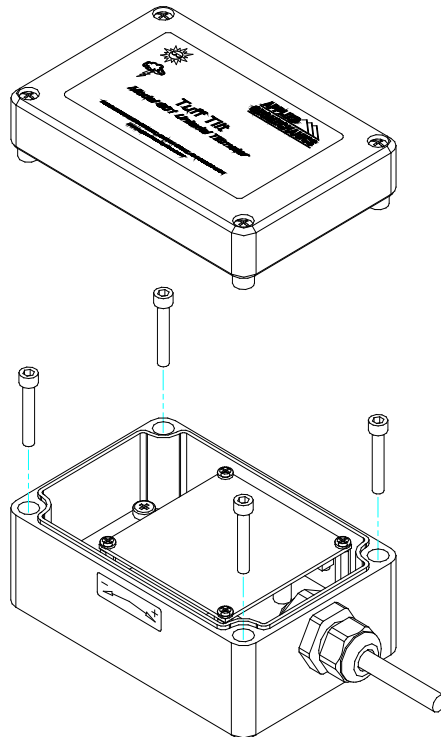

Figure 4. Mounting Screw Insertion

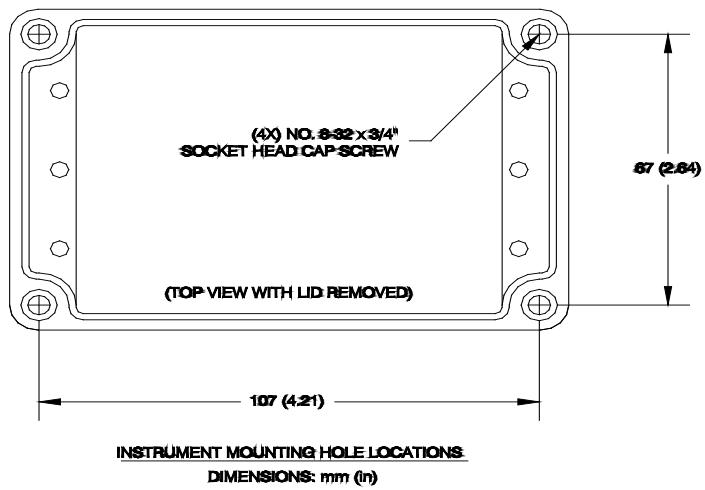

Figure 5. Mounting Hole Pattern

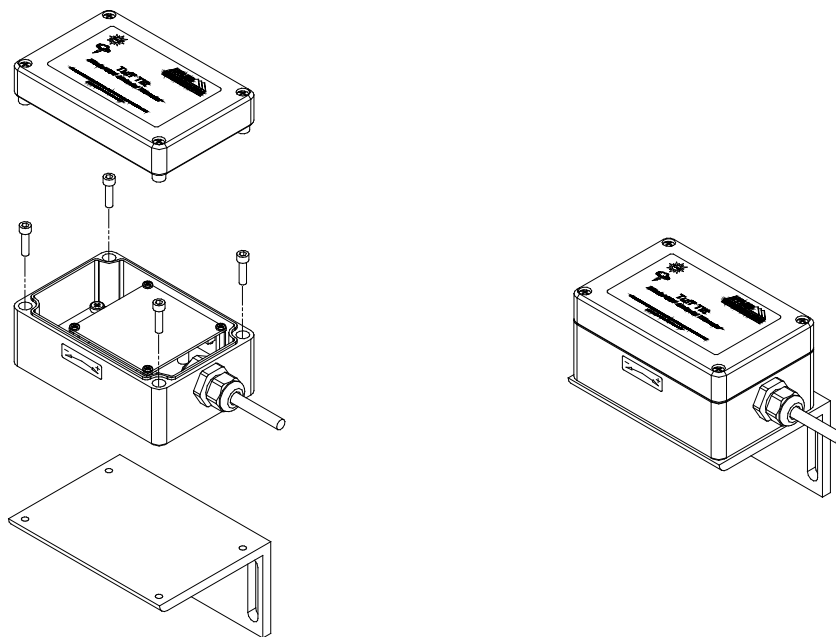

Figure 6. Using P/N 81439 Mounting Bracket

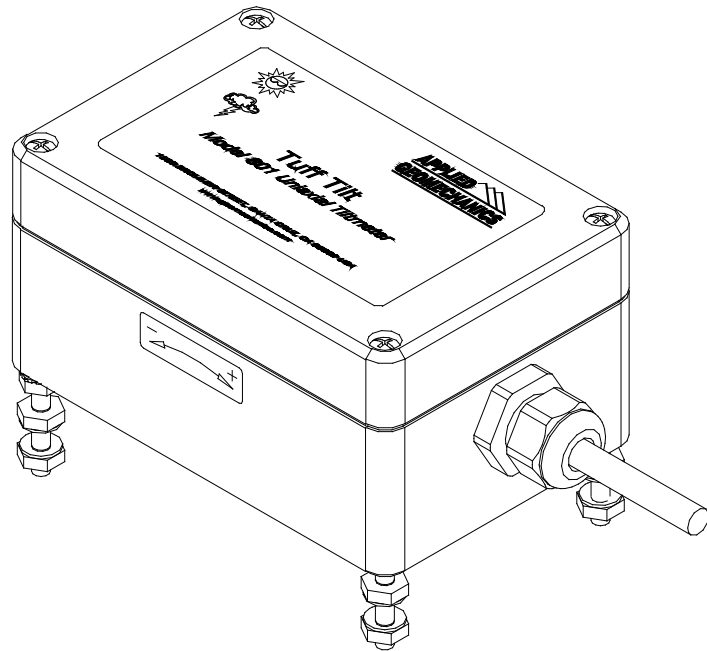

Figure 7. Double Nutting Mounting Screws for Fine Level Adjustment

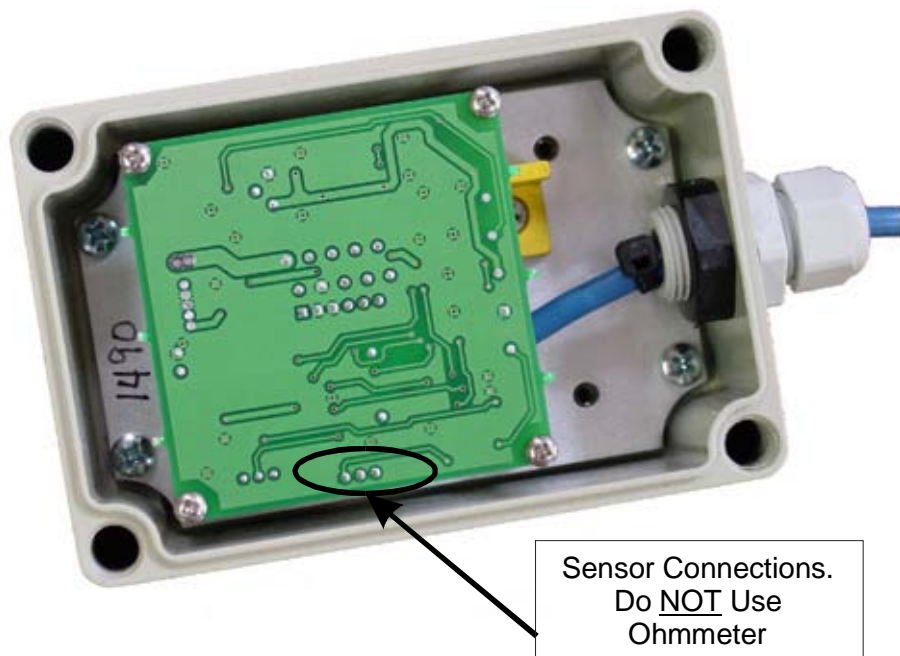

Figure 8. Circuit Board Inside Model 801 Enclosure

## Appendix A. Custom Specifications for Your Equipment; Connectors and Wiring

Serial number: \_\_\_\_\_

- Model 801-H/L [High-gain ( $\pm 0.5^\circ$  range), Longitudinal configuration]
- Model 801-H/T [High-gain ( $\pm 0.5^\circ$  range), Transverse configuration]
- Model 801-S/L [Standard ( $\pm 3^\circ$  range), Longitudinal configuration]
- Model 801-S/T [Standard ( $\pm 3^\circ$  range), Transverse configuration]
- Model 801-W/L [Wide-angle ( $\pm 50^\circ$  range), Longitudinal configuration]
- Model 801-W/T [Standard ( $\pm 50^\circ$  range), Transverse configuration]

### Scale Factors

Single-ended tilt output is measured between the green and white wires in the tiltmeter cable (PN 70369). Differential output is measured between the green and blue wires (see table, next page). The scale factor for differential output is one half the scale factor for single-ended output. Scale factors are determined by linear regression with a minimum of 10 steps over the calibration range. Nonlinearity is the maximum deviation of any point from the regression line, divided by the calibration span ( $\pm 0.5$  degree angular range = 1.0 degree span), expressed as percent.

Calibration Data For Your Tiltmeter					
The scale factor below is:		1 single-ended	1 differential		
SCALE FACTOR		$\mu$ radians/mV	arc second/mV	arc minute/mV	degree/volt
Calibration Temperature		$^\circ$ Celsius			
Max. nonlinearity	%				
Calibrated over Angular Range of	$\pm$	$\mu$ radians	arc second	arc minute	degrees

Temperature sensor output (single-ended only) is measured between the yellow and white wires in the tiltmeter cable. Temperature sensor scale factor is  $0.1^\circ\text{C}/\text{mV}$ .  $0 \text{ mV} = 0^\circ\text{C}$

### Filter

Your tiltmeter has a two-pole Butterworth low-pass filter with a roll-off of 12dB per octave (40 dB/decade) above the corner frequency. The time constant ( $\tau$ ) for the filter is listed below. 90% settling time is three time constants. Corner or cutoff frequency ( $f_c$ ) can be calculated as:  $f_c = 1/(2\pi\tau)$ .

$\tau =$  \_\_\_\_\_ seconds

<b>Cable Color Coding</b>			
<b>Wire Color (Model 870 Cable P/N 70308)</b>	<b>Wire Color (PN 70369 Tiltmeter Cable)</b>	<b>Signal/Function</b>	<b>Connector Pin</b>
Red	Red	+12 VDC	A
Orange	White	Signal ground	B
Gray	Black	Power ground	C
Green	Green	+Tilt out	D
—	Blue	-Tilt out	E
Yellow	Yellow	Temperature out	F

Signal and power grounds are common inside the tiltmeter.

<b>Connector Part Nos.</b>	
Connector on Model 801 Tiltmeter Cable (6-pin male receptacle)	P/N 62204
Connector on Model 870 Readout Module (6-socket female plug)	P/N 62202

<b>ANGLE CONVERSION CHART</b>						
	<b>degrees</b>	<b>arc minutes</b>	<b>arc seconds</b>	<b>μradians</b>	<b>mm/meter</b>	<b>inches/ft</b>
<b>1 degree =</b>	1	60	3600	17453	17.453	0.2094
<b>1 arc minute =</b>	0.01667	1	60	290.9	0.2909	3.49x10 <sup>-3</sup>
<b>1 arc second =</b>	2.78x10 <sup>-4</sup>	0.01667	1	4.848	4.85x10 <sup>-3</sup>	5.82x10 <sup>-5</sup>
<b>1 μradian =</b>	5.73x10 <sup>-5</sup>	3.44x10 <sup>-3</sup>	0.2063	1	0.001	1.20x10 <sup>-5</sup>
<b>1 mm/meter =</b>	0.0573	3.436	206.3	1000	1	0.0120
<b>1 inch/ft =</b>	4.775	286.5	17189	83333	83.33	1