

Model 802 DeepWater Submersible Tiltmeter



140 Chestnut Street
San Francisco, CA 94111
Phone: 415-364-3200
Fax: 415-861-1448
www.geomechanics.com
sales@geomechanics.com

WARNING!

NEVER USE AN OHMMETER TO MEASURE THE TILT SENSORS INSIDE THE TILTMETER. APPLYING DC CURRENT THROUGH THE SENSORS WILL CAUSE PERMANENT DAMAGE THAT IS NOT COVERED BY THE WARRANTY.

Copyright ©2009 by Applied Geomechanics Inc. All rights reserved.
Manual No. B-03-1004, Rev. B. Printed in USA.

TABLE OF CONTENTS

1. Introduction	1
2. Technical Features	1
3. Specifications	2
4. Tiltmeter Operation	3
4.1 INITIAL CHECK-OUT PROCEDURES	3
4.2 TILTMETER INSTALLATION	3
4.3 RECORDING TILTMETER DATA WITH EXTERNAL RECORDERS	3
5. Converting Voltage Readings to Tilt Angles and Temperatures	4
6. Grounding and Transient Protection	4
7. Maintenance and Troubleshooting	5
7.1 ROUTINE MAINTENANCE	5
7.2 CONNECTOR MAINTENANCE	5
7.3 DETERMINING THE CAUSE OF MALFUNCTIONS	6
8. Warranty and Assistance	6
Appendix A. Custom Specifications for Your Equipment;	11
A.1 SCALE FACTORS	11
A.2 FILTER	12
A.3 CONNECTORS AND CABLE	12
A.4 ANGLE CONVERSION CHART	13

LIST OF FIGURES

Figure 1. Model 802 DeepWater Tiltmeter	7
Figure 2. High-Pressure Connector and Cable Whip	7
Figure 3. Tiltmeter with Longitudinal Tilt Configuration	8
Figure 4. Tiltmeter with Transverse Tilt Configuration	8
Figure 5. Model 802 DeepWater Dimensions in Inches (mm)	9
Figure 6. Model 802 DeepWater Mounting Hole Pattern	9
Figure 7. Sensor Connections Inside the Model 802 DeepWater Tiltmeter	10
Figure 8. Face View of Male Connector on Tiltmeter	12

1. Introduction

The Model 802 **DeepWater** is a precision uniaxial tiltmeter designed for underwater tilt measurements and other applications involving high external pressures (Figure 1). Model 802 offers unrivaled sensitivity and long-term stability under these demanding conditions. The 316 stainless steel housing encloses stable, low-noise electronics and an electrolytic tilt sensor, which is the internal sensing element. Measured angular movement is referenced to the unchanging vertical gravity vector, eliminating the time and expense of locating an external datum. **DeepWater** tiltmeters are an excellent choice for monitoring the behavior of underwater structures, such as dams, oil platforms and pipelines; measuring the rotational movement of underwater machinery; and tracking the pitch and roll of marine vessels.

2. Technical Features

Your Model 802 **DeepWater** is the newest addition to Applied Geomechanics' line of 800-Series uniaxial tiltmeters, which was first introduced in 1989. Model 802 senses angular movement (rotation) with respect to the vertical gravity vector. The sensing element is an electrolytic tilt transducer, similar to a spirit level. As the transducer tilts, internal electrodes are covered or uncovered by a conductive fluid. This process produces changes in electrical resistance when an AC excitation is passed through the transducer. These changes are measured using a voltage divider network. The resulting signal is then amplified, actively rectified and filtered to form a high-level DC signal that is proportional to the measured angular rotation, or tilt. Both single-ended *and* differential tilt outputs are provided.

High-reliability components and surge protection enhance tiltmeter performance under electrically noisy or transient-prone conditions. A 2-pole Butterworth low-pass filter removes vibration effects for static measurements. In addition, your tiltmeter contains a built-in temperature sensor with single-ended analog voltage output. This temperature sensor provides the data that can be used for analysis of thermal deformation and stresses.

Your tiltmeter is equipped with a 6-pin male Subconn MicroCircular bulkhead connector for external power and signal connections (Figure 1). This neoprene connector has a depth rating of 700 bars (10,000 psi). The tiltmeter comes with a mating female connector and cable whip (Figure 2). The required cable length is specified when ordering. The pressure rating of the tiltmeter housing is 250 bars (3600 psi).

Model 802 **DeepWater** tiltmeters are produced in high-gain ($\pm 0.5^\circ$ range), standard ($\pm 3^\circ$ range) and wide-angle ($\pm 50^\circ$ range) versions. Each version is available in both longitudinal and transverse tilt configurations to better meet your installation requirements (Figures 3 and 4). The version that you have selected is indicated at the beginning of Appendix A.

Other important features include the following:

- All electronics reside on a single internal printed-circuit board.
- All circuit board external connections are gold-plated for long life and noise-free operation.
- All resistors are premium quality, 1% tolerance, metal-film type.
- All tiltmeters are assembled, calibrated and tested at our plant under strict quality standards. AGI maintains complete calibration and test records of every tiltmeter built.

3. Specifications

	Model 802-H High-Gain Version	Model 802-S Standard Version	Model 802-W Wide-Angle Version
ANGULAR RANGE	±0.5 degrees	±3 degrees	±50 degrees*
SCALE FACTORS	0.1°/ Volt (single-ended) 0.05°/ Volt (differential)	0.6°/ Volt (single-ended) 0.3°/ Volt (differential)	10°/ Volt (single-ended) 5°/ Volt (differential)
RESOLUTION	<0.0001 degree (<1.75 μradians)	<0.0006 degree (10.5 μradians)	<0.01 degree
REPEATABILITY	<0.0002 degree	0.001 degree	0.02 degree
LINEARITY	1% of full span typical	<2% of full span typical	0.5% of full span typical
TEMPERATURE COEFFICIENT	Scale factor: $K_s < 0.02\%/^{\circ}\text{C}$ typ. Zero shift: $K_z = \pm 0.0002$ degree/ $^{\circ}\text{C}$	$K_s < 0.02\%/^{\circ}\text{C}$ typ. $K_z = \pm 0.0002$ degree/ $^{\circ}\text{C}$ typ.	$K_s < 0.02\%/^{\circ}\text{C}$ typ. $K_z = \pm 0.002$ degree/ $^{\circ}\text{C}$ typ.
TIME CONSTANT, T	1.75 seconds (2-pole Butterworth low-pass filter), faster response available		0.15 second
TILT OUTPUT	± 5 VDC single-ended, ±10 VDC differential (both provided)		
TEMPERATURE OUTPUT	0.1°C/mV (single-ended), -40° to +100°C, ±0.75°C accuracy, 0°C = 0 mV		
OUTPUT IMPEDANCE	270 Ohms, short circuit and surge protected		
POWER REQ'TS.	+8 to +18 VDC @ 8 mA, 250 mV peak-to-peak ripple max., reverse polarity protected		
ENVIRONMENTAL	-25° to +70° C operating, -30° to +100° C storage; submersible to 250 bars (3,600 psi)		
ENCLOSURE & MOUNTING	316 stainless steel enclosure, machined from single block, 149 x 91 x 82 mm (5.85 x 3.56 x 3.20 inches). Four 5.1 mm (0.201 inch) dia. external mounting holes		
SEALS	Nitrile (Buna-N) face seal O-rings in lid and bulkhead connector		
CONNECTORS	6-pin male bulkhead connector, neoprene over brass body; neoprene in-line connector. 700 bars (10,000 psi) depth rating		
CABLE	6-conductors: Either neoprene cable, 20 AWG, no shield or PVC-jacketed, polypropylene-insulated cable, 24 AWG, one overall shield. 2 ft (60 cm) neoprene whip is standard, longer cables on request.		
WEIGHT	5 kg (11 lb)		

* Greater range available

4. Tiltmeter Operation

4.1 Initial Check-Out Procedures

Before installing your tiltmeter, verify that it is functioning properly by following the steps below:

1. Connect the red and black tiltmeter power wires to a suitable power supply (see Specifications) and the output wires to a voltmeter (refer to the pin assignments and wire colors in Appendix A). Or, connect the tiltmeter to a Model 870 Readout Module and voltmeter.
2. If using the Model 870 Readout Module, turn the Readout Module switch to TILT.
3. Refer to the (+) and (–) tilt directions in Figures 3 or 4 (also shown on a label on your tiltmeter). With the tiltmeter in your hands, rotate it to verify the sign (polarity) of the outputs. A rotation in the (+) direction should make the voltage output become more positive. A (–) rotation should make it become more negative.
4. Check that the tiltmeter output moves through its full range of approximately +5 Volts to -5 Volts (single-ended) or +10 Volts to -10 Volts (differential). When using the Model 870 Readout Module, the output that is displayed on the voltmeter is single-ended. Note that the positive output is typically greater than +5 Volts (single-ended) or +10 Volts (differential).
5. Next, connect the voltmeter to the temperature output and signal ground (see Appendix A), or turn the Readout Module switch to TEMPERATURE. Verify that the temperature sensor output approximates the temperature in your location. For example, a room temperature of 20°C (68°F) should give a voltage output of 200 mV (0.200 volts). The temperature sensor scale factor is 0.1°C/mV.

If your results do not conform to these guidelines, check your procedure and repeat the measurement sequence above. If you are still unable to successfully complete the check-out procedure, contact Applied Geomechanics for assistance.

4.2 Tiltmeter Installation

Your Model 802 **DeepWater** tiltmeter is designed to be mounted directly onto a solid horizontal surface using four No. 10 or M4 screws. External holes in the submersible stainless steel case are provided for mounting the tiltmeter (Figures 5 and 6). The surface may be drilled and tapped to accept the screws, or through-holes may be drilled and the screws attached with nuts and washers on the underside of the surface.

4.3 Recording Tiltmeter Data with External Recorders

The analog output of your Model 802 **DeepWater** tiltmeter is readily measured by a variety of external devices, including digital voltmeters, oscilloscopes, strip-chart recorders, data-

loggers, and PC-based data acquisition systems. Just connect your tiltmeter cable to a suitable external power supply and to the inputs of your recording device. Refer to the cable color coding table in Appendix A for the information you will need to make these connections.

5. Converting Voltage Readings to Tilt Angles and Temperatures

The tiltmeter voltage outputs are quickly converted to tilt angles as follows: Multiply the voltage reading by the scale factor in Appendix A. For example, if the scale factor is 0.600 degree/Volt and the voltage reading is +2.000 Volts, then the tilt angle is +1.200 degrees from sensor null.

Similarly, the voltage reading from the tiltmeter temperature sensor is converted to temperature by multiplying it by a scale factor of 0.1°C/mV (100°C/Volt), with 0 mV = 0°C.

6. Grounding and Transient Protection

Your tiltmeter has separate power ground and signal ground wires in the tiltmeter cable. Both are connected (common) inside the tiltmeter. Signal Ground is the reference state for single-ended tilt measurements and for temperature measurements. *We recommend that you do not connect the Power Ground and Signal Ground wires at your power supply or recorder.* Current needed to power the tiltmeter flows in the power ground wire and, as predicted by Ohm's Law, the ground potential is different at opposite ends of this wire because of wire resistance. By keeping signal ground separate from power ground, your tilt and temperature readings will not be affected by this potential difference.

If you ground the power ground wire to earth, do so at one end only. Earthing in more than one location can produce ground loops and create unstable readings.

Variable resistance type surge absorbers connect each wire in the tiltmeter cable to the metal enclosure (case) that houses your tiltmeter. If operated in salt water, the tiltmeter case will be well grounded. If operated on land, connecting the enclosure to a grounding rod, or other form of earth ground, will reduce the likelihood of an electronic failure caused by high-voltage transients. Such transients can be caused by nearby lightning strikes or unstable power sources. Grounding the cable shield (PVC jacketed cables only) to earth at the power supply end can also help avoid transient-induced damage and can reduce noise in your measurements. Note that the cable shield is terminated at the tiltmeter end and is not connected to the metal tiltmeter enclosure.

High-voltage transients are the most common cause of failure of field instruments in outdoor installations. In a typical occurrence, a high-voltage spike from a lightning strike or power surge travels along the cable until it encounters the instrument's electronic circuitry, where the delicate low-voltage components are overloaded and fail. The protections provided in your tiltmeter reduce the likelihood of failure. Commercially available surge suppression circuitry can provide additional protection.

7. Maintenance and Troubleshooting

7.1 Routine Maintenance

The routine maintenance procedures given here will help ensure that your **DeepWater** tiltmeter provides many years of trouble-free service.

Keep your tiltmeter clean and away from extremes of heat and cold. Dirt and extreme temperatures shorten the life of the seals and unnecessarily stress the electronic components. *Keep the tiltmeter out of direct summer sun because solar radiation can create internal temperatures much higher than the ambient temperature – in some cases higher than the rated storage temperature of the tiltmeter.*

To ensure that your tiltmeter maintains its waterproof seal, make sure that the connector and the screws securing the lid are tight before submergence. The O-ring in the lid is made of nitrile (Buna-N) and can be replaced if damaged by Parker O-ring size 2-247. The O-ring should be lubricated with a light coating of silicon grease such as Dow Corning 112 or Molykote 44 Medium.

The electrolytic tilt sensor in your tiltmeter is a stable, robust and shock tolerant device. One of the few things that can damage it is Direct Current (DC), which causes electrolysis and plating of the electrodes. Figure 7 shows the sensor connections to the circuit board. *NEVER* use an ohmmeter (which uses DC) at these locations.

WARNING!

NEVER USE AN OHMMETER TO MEASURE THE TILT SENSORS INSIDE THE TILTMETER. APPLYING DC CURRENT THROUGH THE SENSORS WILL CAUSE PERMANENT DAMAGE THAT IS NOT COVERED BY THE WARRANTY.

7.2 Connector Maintenance

The following handling procedures should be adopted to achieve the best performance from your tiltmeter's high-pressure connectors (courtesy of Subconn Inc.):

- Do not expose the connectors to long-term heat or sunshine. If this occurs, and the connectors are very dry, soak in fresh water before use.
- Keep the connectors lubricated. The recommended lubricant is Molykote 44 Medium. Use sparingly – half a match head per contact is adequate.
- Sand or mud in the female contact should be removed with fresh water. Failure to do so could result in splaying of the female contact and damage to the O-ring seals.
- Do not overtighten the bulkhead nut.
- Do not disconnect by pulling on the cable. Avoid sharp bends at cable entry.

- When disconnecting, pull straight, not at an angle.
- Do not apply angular loads (shears) to the bulkhead connector, as they can damage or destroy the connector.

7.3 Determining the Cause of Malfunctions

Apart from the procedures described below, your Model 802 **DeepWater** tiltmeter is not field serviceable. If you encounter problems not described here, please contact Applied Geomechanics Inc. at telephone (831) 462-2801, fax (831) 462-4418 or email us at service@geomechanics.com. A service engineer will assist you in determining the cause of any problem.

If there is no output when the tiltmeter is connected to a power supply (or to the Model 870 Readout Module), first check that your multimeter or recording device has adequate power and is functioning properly. Then check the power supply to be sure that it is providing power to the tiltmeter. Verify that all connectors are securely attached. *Failure to obtain an output signal from the tiltmeter normally is the result of lack of power or a broken wire or connection.*

If the tiltmeter output is firmly “pegged” at either end of its output range, the tiltmeter is probably tilted off scale. Rotate the tiltmeter in the opposite tilt direction to check this possibility. The tiltmeter output should pass through zero volts as you move it through its null (level) position. Remember that the response is not instantaneous because of the time constant of the filter. However, no more than a few seconds should elapse before the tiltmeter responds as it moves through null.

If the tiltmeter output remains “pegged” at its positive or negative limit no matter how much you move it, the cause may be a broken connection or short circuit where the sensor lead wires connect to the printed circuit board (Figure 7). *Do not use an ohmmeter to check the sensor connections, as doing so will permanently damage the sensor.* Visually inspect the lead wires and circuit board connector to verify that the connections are properly made. If this inspection still fails to identify the problem, contact the factory for assistance or to arrange for a repair.

8. Warranty and Assistance

Your Model 802 **DeepWater** tiltmeter is warranted against defects in materials and workmanship for one year from the date of delivery. We will repair or replace (at our option) products that prove to be defective during the warranty period provided they are returned prepaid to Applied Geomechanics Inc. (AGI). No other warranty is expressed or implied. The warranty is void if the equipment is subjected to lightning strikes or other large potential gradients, or if it is otherwise used contrary to the directions herein. After expiration of the warranty, AGI will repair the equipment at its factory for parts and labor charges. Products returned after warranty expiration should be accompanied by a purchase order to cover repair costs. Applied Geomechanics Inc. is not liable for consequential damages.

THE REMEDIES PROVIDED HEREIN ARE THE BUYER’S SOLE AND EXCLUSIVE REMEDIES. AGI SHALL NOT BE LIABLE FOR ANY DIRECT, INDIRECT, SPECIAL, INCIDENTAL OR CONSEQUENTIAL DAMAGES, WHETHER BASED ON CONTRACT, TORT OR ANY OTHER LEGAL THEORY.



Figure 1. Model 802 *DeepWater* Tiltmeter

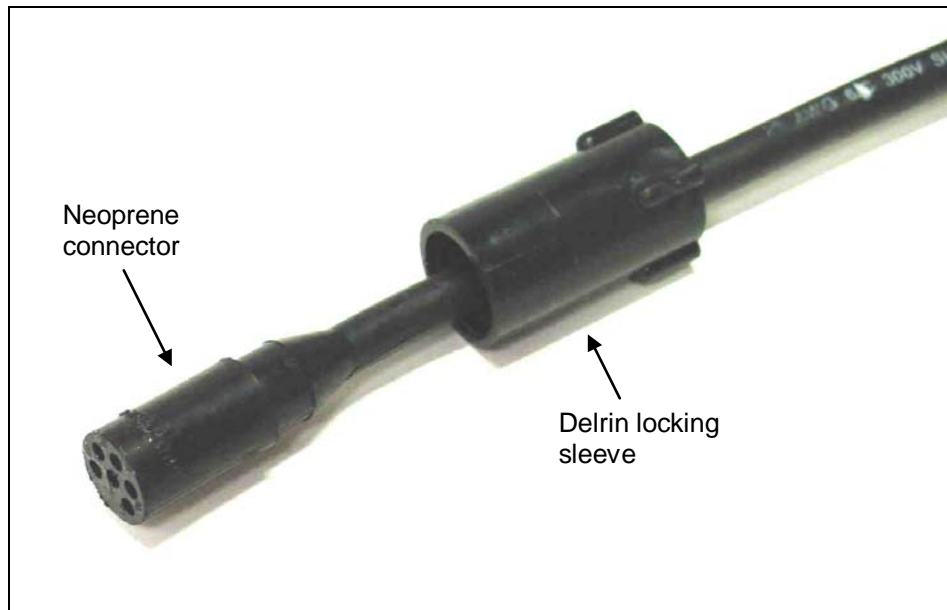
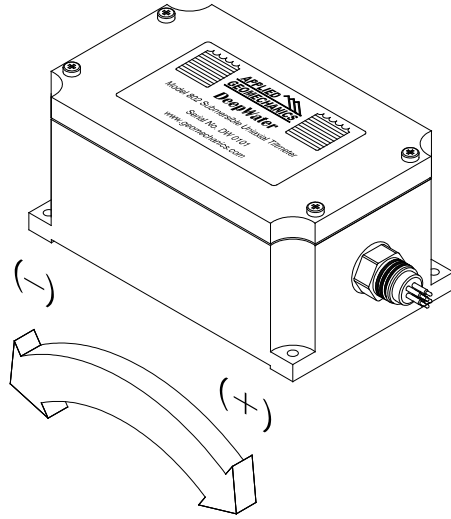
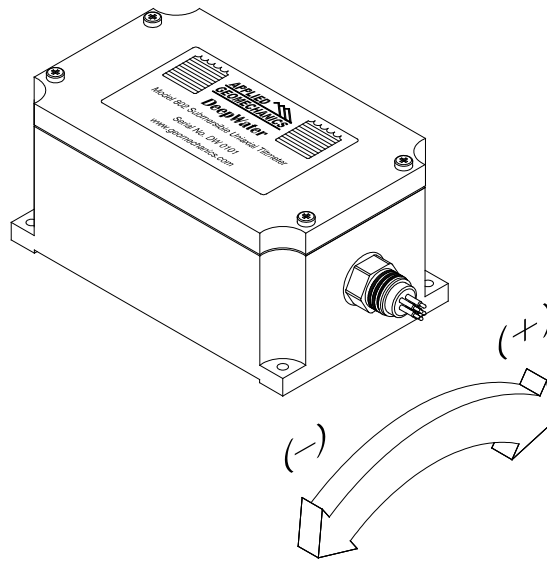

Figure 2. High-Pressure Connector and Cable Whip



LONGITUDINAL
CONFIGURATION

Figure 3. Tiltmeter with Longitudinal Tilt Configuration



TRANSVERSE
CONFIGURATION

Figure 4. Tiltmeter with Transverse Tilt Configuration

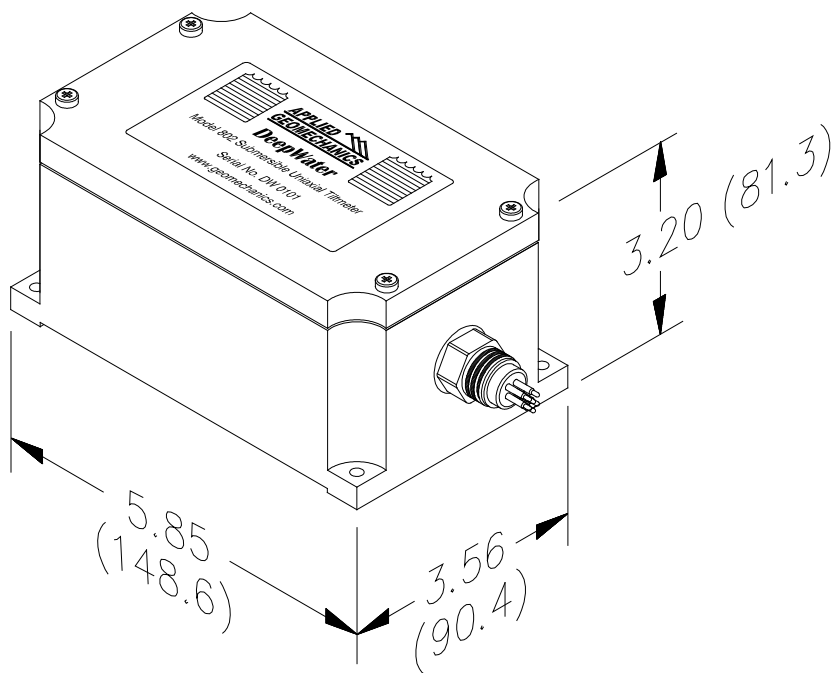

Figure 5. Model 802 *DeepWater* Dimensions in Inches (mm)

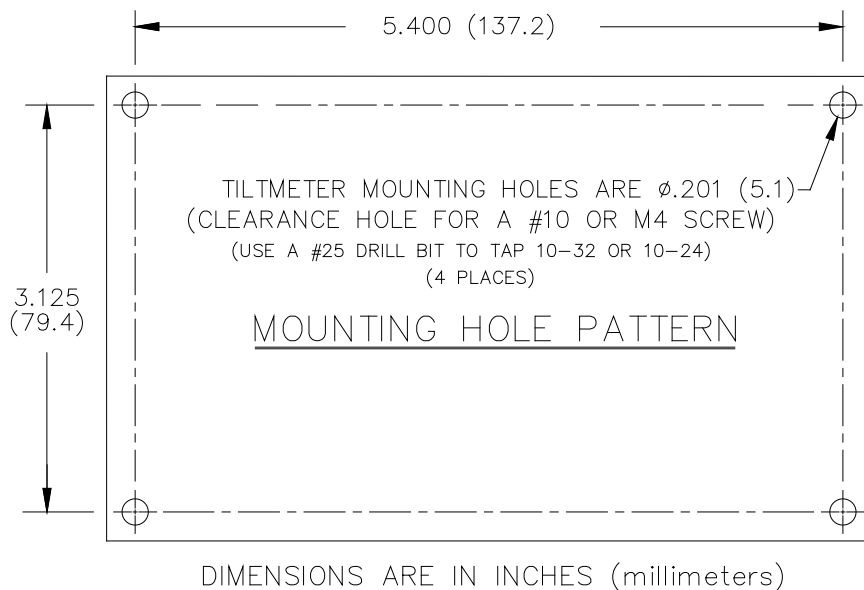

Figure 6. Model 802 *DeepWater* Mounting Hole Pattern

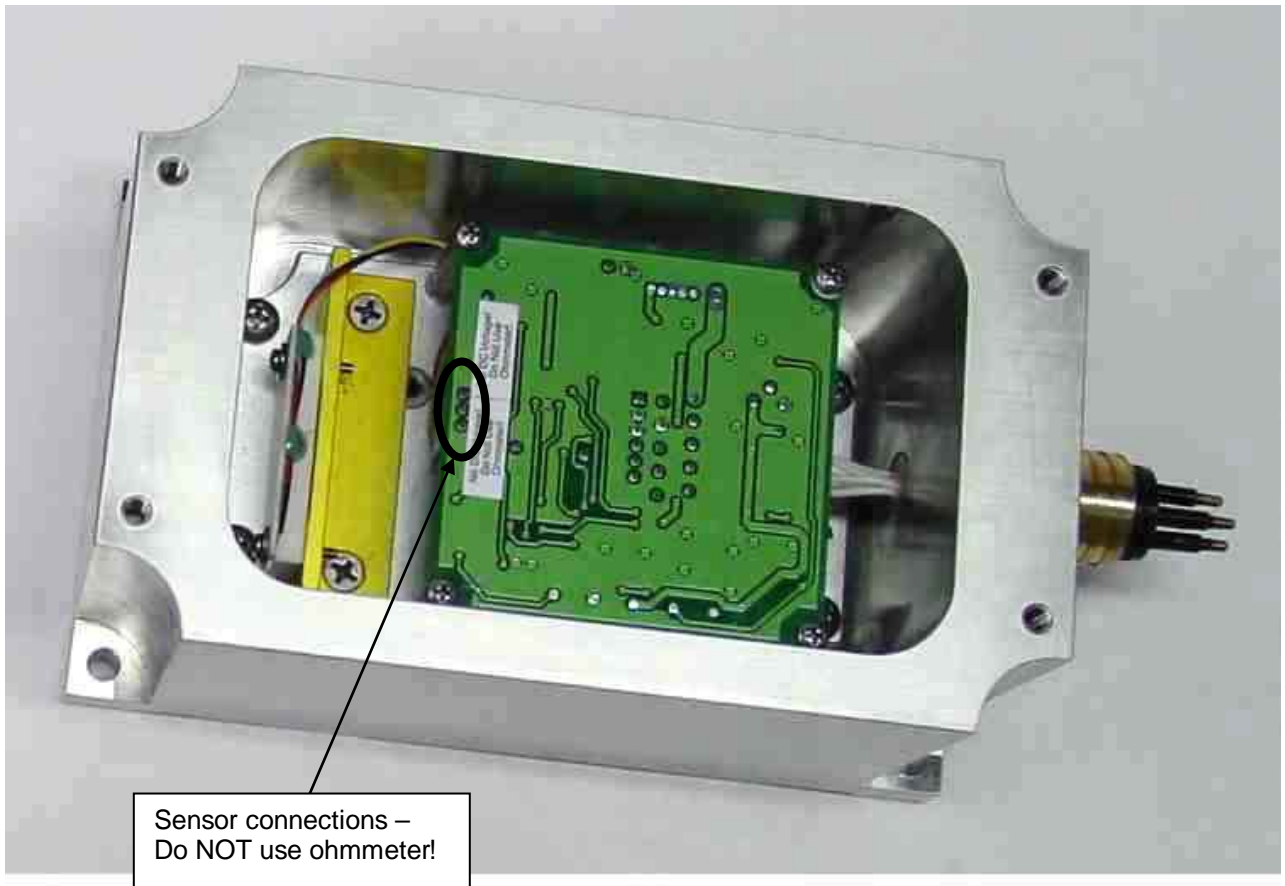

Figure 7. Sensor Connections Inside the Model 802 *DeepWater* Tiltmeter

Appendix A. Custom Specifications for Your Equipment; Connectors and Wiring

Serial number: _____

- Model 802-H/L [High-gain ($\pm 0.5^\circ$ range), Longitudinal configuration]
- Model 802-H/T [High-gain ($\pm 0.5^\circ$ range), Transverse configuration]
- Model 802-S/L [Standard ($\pm 3^\circ$ range), Longitudinal configuration]
- Model 802-S/T [Standard ($\pm 3^\circ$ range), Transverse configuration]
- Model 802-W/L [Wide-angle ($\pm 50^\circ$ range), Longitudinal configuration]
- Model 802-W/T [Standard ($\pm 50^\circ$ range), Transverse configuration]

A.1 Scale Factors

Single-ended tilt output is measured between connector pins 4 and 2 (green and white wires in cable whip). Differential output is measured between connector pins 4 and 6 (green and blue wires in cable whip, see table, next page). The scale factor for differential output is one half the scale factor for single-ended output. Scale factors are determined by linear regression with a minimum of 10 steps over the calibration range. Nonlinearity is the maximum deviation of any point from the regression line, divided by the full calibration span (± 0.5 degree angular range = 1.0 degree span), expressed as a percentage of full span.

Calibration Summary for Your Tiltmeter					
The scale factor below is:		<input type="checkbox"/> Single-ended		<input type="checkbox"/> Differential	
SCALE FACTOR		μ radians/mV	arc second/mV	arc minute/mV	degree/Volt
Calibration Temperature		$^\circ$ Celsius			
Max. nonlinearity	% of full span				
Calibrated over Angular Range of	\pm	μ radians	arc seconds	arc minutes	degrees

Temperature sensor output (single-ended only) is measured between the yellow (orange) and white wires (pins 5 and 2). Temperature sensor scale factor is 0.1 $^\circ$ C/mV. 0 mV = 0 $^\circ$ C.

A.2 Filter

Your tiltmeter has a two-pole Butterworth low-pass filter with a roll-off of 12dB per octave (40 dB/decade) above the corner frequency. The time constant (τ) for the filter is listed below. 90% settling time is three time constants. Corner or cutoff frequency (f_c) is calculated as: $f_c = 1/(2\pi\tau)$.

$\tau =$ _____seconds

A.3 Connectors and Cable

Your Model 802 **DeepWater** tiltmeter uses the following connectors:

	Subconn Part No.	AGI Part No.
Bulkhead Connector (male)	MCBH6M	00357
In-Line Connector (female) on Cable Whip	MCIL6F	00358
Delrin Locking Sleeve (female)	MCDLSF	00359

Two kinds of cable are available on the cable whip: 1) Neoprene SO cable with 20 AWG conductors or 2) PVC-jacketed, polypropylene-insulated cable with 24 AWG conductors. In some cable whips the PVC-jacketed cable is joined to the neoprene cable with a waterproof splice. The table below gives the wire color coding and connector pin assignments. A drawing of the connector pin configuration follows the table.

Connector Pin	Wire Color in Cable	Function
1	Black	Power Ground*
2	White	Signal Ground*
3	Red	+8 to +18 Volts DC
4	Green	+ Tilt
5	Yellow (Orange)	Temperature
6	Blue	- Tilt

* Signal and power grounds are common inside the tiltmeter.

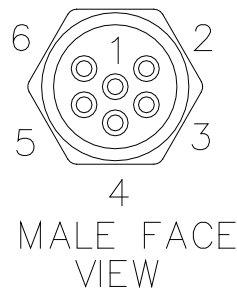

Figure 8. Face View of Male Connector on Tiltmeter

A.4 Angle Conversion Chart

	degrees	arc minutes	arc seconds	μradians	mm/meter	inches/ft
1 degree =	1	60	3600	17453	17.453	0.2094
1 arc minute =	0.01667	1	60	290.9	0.2909	3.49×10^{-3}
1 arc second =	2.78×10^{-4}	0.01667	1	4.848	4.85×10^{-3}	5.82×10^{-5}
1 μradian =	5.73×10^{-5}	3.44×10^{-3}	0.2063	1	0.001	1.20×10^{-5}
1 mm/meter =	0.0573	3.436	206.3	1000	1	0.0120
1 inch/ft =	4.775	286.5	17189	83333	83.33	1